

C-155
P/N 122648C
REVISION C
5/03

DESPATCH 900 SERIES CHAMBER EQUIPMENT MANUAL

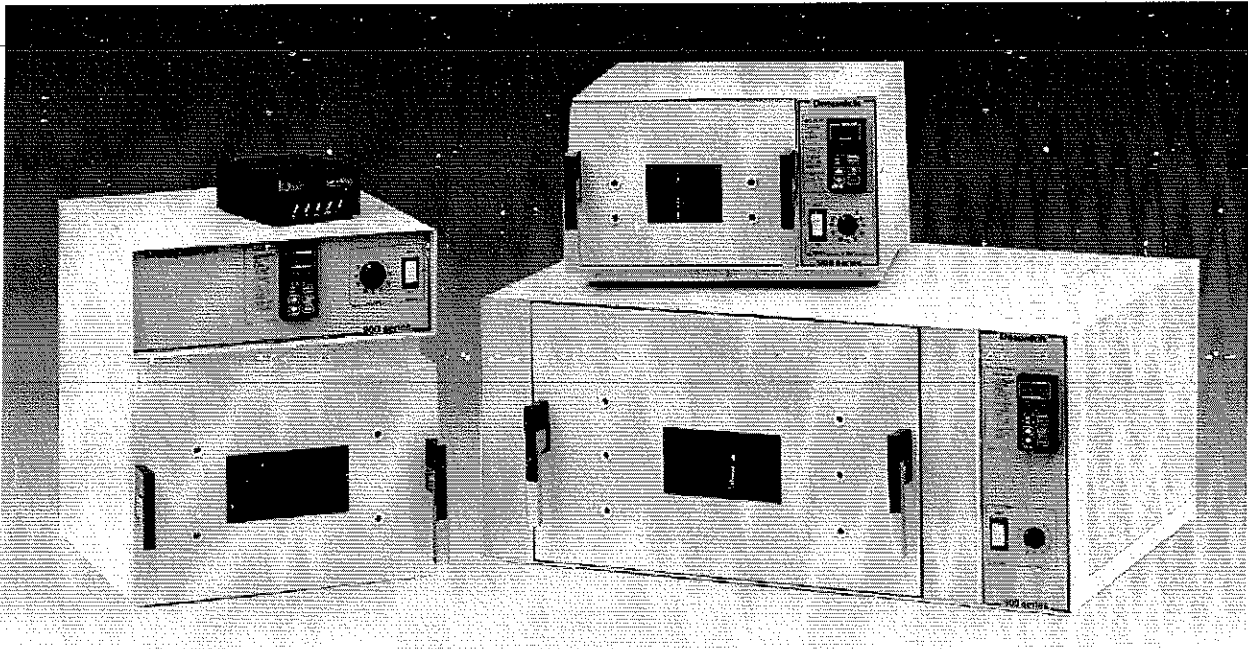

Prepared by:
Despatch Industries
P.O. Box 1320
Minneapolis, MN 55440-1320
Customer Service 800-473-7373

Notice

Users of this equipment must comply with operating procedures and training of operation personnel as required by the Occupational Safety and Health Act (OSHA) of 1970, Section 6 and relevant safety standards, as well as other safety rules and regulations of state and local governments. Refer to the relevant safety standards in OSHA and National Fire Protection Association (NFPA), section 86 of 1990.

Caution

Setup and maintenance of the equipment should be performed by qualified personnel who are experienced in handling all facets of this type of system. Improper setup and operation of this equipment could cause an explosion that may result in equipment damage, personal injury or possible death.

Thank you for choosing Despatch Industries. We appreciate the opportunity to work with you and to meet your heat processing needs. We believe that you have selected the finest equipment available in the heat processing industry.

At Despatch, our service does not end after the purchase and delivery of our equipment. For this reason we have created the Service Products Division within Despatch. The Service Products Division features our Response Center for customer service. The Response Center will direct and track your service call to ensure satisfaction.

Whenever you need service or replacement parts, contact the Response Center at 1-800-473-7373; FAX 612-781-5353.

Thank you for choosing Despatch.

Sincerely,

Despatch Industries

Standard Products Product Warranty

Products Covered by this Warranty

This warranty (the "Warranty") applies to the following Despatch products: LEB, LBB, LAC, LCC, LCD, LLC, LLD, RAD, RFD, LND, RTFO, TAD, TFD, PR, PN, PW, PTC and the following Ransco products: RTH, RTS, 900 Series.

Parts and Materials

Despatch warrants all parts and materials to be free from defects in material and workmanship for a period of:

1. five (5) years from date of shipment for laboratory oven electric heaters;
2. three (3) years from date of shipment for Protocol Plus and DES 2000 temperature controllers; and
3. one (1) year from the date of shipment, or 2,000 hours of operation, whichever occurs first, for all other components of products covered by this Warranty.

During the applicable Warranty period, Despatch will repair or replace, at Despatch's option, parts and materials covered by this Warranty

Labor

During the first 90 days of the Warranty period, Despatch will pay labor costs incurred to remove defective parts and materials, and to reinstall repaired or replacement parts or materials; provided, however, that Despatch's obligation to pay such labor costs shall be subject to the limitation that the removal and/or reinstallation service must be performed by a Despatch-authorized technician from Despatch's worldwide network of factory-trained professionals at a location within the contiguous United States.

Transportation Costs

All transportation costs to transport defective parts or materials to Despatch, and to transport repaired or replacement parts or materials to Customer, shall be the responsibility of the Customer.

Terms and Conditions

This Warranty shall be deemed valid and binding upon Despatch if and only if the Customer:

1. installs, loads, operates, and maintains the covered product supplied hereunder in accordance with the instruction manual provided upon delivery and product labeling affixed to the subject equipment;
2. if applicable, follows the Emergency Procedure set forth in this Warranty; and
3. contacts Despatch's Helpline at 1-800-473-7373 for assistance in diagnosing and troubleshooting the problem immediately upon discovering any damage or malfunction.

Despatch's reasonable determination as to whether a repair, replacement, or service is covered by this Warranty shall be final and binding.

Exclusions

This Warranty DOES NOT cover:

1. damage or malfunctions, or expenses incurred in the process of diagnosing and/or repairing damage or malfunctions, resulting from any of the following: operator error, misuse, abuse,

inadequate preventive maintenance, normal wear and tear, service or modifications by other than Despatch authorized technicians, use of the covered product that is inconsistent with the operation manual or labeling, acts of nature (including, without limitation, floods, fire, earthquake, or acts of war or civil emergency), internal or external corrosion, or non-conforming utilities (including, without limitation, electrical, fuel supply, environmental and intake/exhaust installations);

2. repair or replacement of parts or materials designed and intended to be expendable or consumable;
3. routine maintenance; or
4. labor costs incurred for troubleshooting, diagnostics, or testing (except for testing required to verify that a covered defective part or material has been repaired).

Limitations of Liability

Despatch shall not, in any event, be liable for indirect, special, consequential, incidental, or punitive damages or penalties of any kind, including, without limitation loss of revenue, profits or business opportunities resulting from interruption of process or production. In no event shall Despatch be liable for damages in excess of the amounts paid by Customer to Despatch with respect to the applicable product(s). This Warranty does not cover, and Despatch shall not be liable for any losses, costs, damages or expenses resulting from delays in diagnosing or repairing the products, supplying or obtaining replacement parts or materials, strikes, labor stoppages or shortages, fires, accidents, government acts or regulations, or any other causes beyond the control of Despatch.

Non-Compliance By Customer

Despatch reserves the right to suspend and withhold service under this Warranty in the event of non-compliance by the Customer to any terms and conditions of this Warranty or the applicable purchase order or invoice. Further, Despatch shall not be liable for any loss of production, expenses, and inconveniences incurred due to such suspension.

Customer Furnished Equipment Warranty Limitation

This Warranty does not cover diagnosis or repairs of defects in or caused by, lack of performance of, or fitness for purpose of customer-supplied parts or equipment unless specifically noted in the Despatch written order acceptance confirmation.

Performance Commitment

Despatch provides no guarantee of process performance or fitness for purpose, unless specifically noted otherwise in Despatch written order acceptance confirmation. Despatch is providing equipment with design parameters specific only to its equipment.

Procedure Upon Discovery of Defects and Emergencies

In the event Customer becomes aware of any defect in the applicable products, Customer must immediately: (a) shut off fuel or energy supply (gas and electricity), (b) call for emergency assistance, if needed, and (c) notify Despatch Service.

THE REPRESENTATION AND WARRANTIES SET FORTH HEREIN ARE EXCLUSIVE AND IN LIEU OF, AND CUSTOMER HEREBY WAIVES AND DISCLAIMS RELIANCE UPON, ALL OTHER REPRESENTATIONS AND WARRANTIES OF EVERY KIND WHATSOEVER, WHETHER EXPRESS OR IMPLIED, OR ARISING BY OPERATION OF LAW OR IN EQUITY, OR BY COURSE OF PERFORMANCE OR DEALING OR USAGE OF TRADE, INCLUDING, WITHOUT LIMITATION, ANY IMPLIED WARRANTIES OF MERCHANTABILITY OR OF FITNESS FOR A PARTICULAR PURPOSE.

THIS WARRANTY IS PERSONAL TO THE CUSTOMER AND MAY NOT BE TRANSFERRED OR ASSIGNED. ALL LIMITATIONS HEREUNDER, HOWEVER, SHALL BE BINDING ON ALL SUCCESSORS AND ASSIGNS OF CUSTOMER.

Service

Worldwide Phone 612-781-5356; Worldwide Fax 612-781-5485; North American Phone 800-473-7373
e-mail service@despatch.com; www.despatch.com

Despatch Industries

Advantage Service Assurance Program (ASAP)

CONTACT: DESPATCH SERVICE AGREEMENTS SPECIALIST at 800-473-7373 or 612-781-5356
or e-mail: service@despatch.com

Despatch continues to deliver exceptional products backed by a strong sense of responsibility and drive for long term customer satisfaction. Your partnership with Despatch can offer even higher value through your subscription to one of Despatch's Advantage Service Assurance Program(ASAP).

Warranty

Despatch's exclusive, comprehensive service programs start with the 1 year parts only warranty which is described on the other side of this document. This warranty can be expanded immediately to meet your most stringent service needs. Despatch Service Products Group will be able to answer your service questions and provide a quotation for the immediate expansion of your product warranty. Call 800-473-7373 or 612-781-5356; or e-mail service@despatch.com.

Immediate Service Response

The key to an effective service program is response. Wherever your location, Despatch is only a phone call away. Our U.S. and Canadian customers can reach Despatch at 1-800-473-7373. Worldwide customers can call 1-612-781-5356 or FAX 1-612-781-5485. Our Customer Service Technicians have over 150 years combined experience and access to detailed design and manufacturing documentation specific to your Despatch unit(s). This exacting level of service is a benefit only Despatch can provide and means that you can expect speedy, accurate and the most cost effective response.

Field Service Network

A worldwide network of factory trained Service Professionals is available to support your Despatch equipment. From routine repair to certified instrument calibration, the Despatch service network is positioned to respond to your needs. As a manufacturer of custom equipment, our service programs are customized to meet your specific needs regarding:

1. Service scope
2. Response time
3. Preventive maintenance frequency and content
4. Payment method

Sustained Service Support

At Despatch, long term customer satisfaction means more than just responding quickly and effectively to our customers' service needs. It means offering comprehensive customer support well beyond the scope and duration of our initial warranty. Despatch offers two basic service packages which are customized to each individual customer's need. These service packages are titled Full Service and Preventive Maintenance Plus+ service agreement products. Each is unique in the industry and offer the following benefits:

1. Priority response for minimum production interruption
2. Preventive maintenance for longer product life
3. Discounts on parts and services
4. Various payment plans to ease budgeting and recording expenses
5. Reduce purchase ordering costs

PREFACE

This manual contains instructions for all accessories available on the Despatch 900 Series Environmental Bench Chamber. You may want to mark the parts of the manual that are applicable to your particular oven.

The INTRODUCTION provides a brief overview of options available for the Despatch 900 Series Environmental Bench Chamber.

The INSTRUCTIONS cover the installation and operation of the 900 Series Environmental Bench Chamber.

The THEORY OF OPERATION provides detailed technical information on the heating system, the cooling system, condensation and corrosion.

The MAINTENANCE section contains technical information and checklists for maintaining the equipment.

The APPENDIX contains tables for Troubleshooting, Temperature/RH%/Pressure Equations, Humidity Conversion Tables, Wet Bulb Depression - % RH Conversion Table and the Industrial Equipment Commercial Warranty.

NOTE:

Refer to the Despatch Ecosphere Series Environmental Chamber Operating Instruction for programming instructions.

Revision B: Updated schematic diagrams

Revision C: Update Despatch Product Warranty

TABLE OF CONTENTS

PREFACE	i
INTRODUCTION	1
230 Volt, 50/60 HZ Operation	1
Specifications	2
INSTRUCTIONS	3
Operator Training Requirements	3
Installation	4
Installation of Cooling Gas	6
Installation of Carbon Dioxide	7
Liquid CO ₂ Cylinder Installation	11
Installation of Liquid Nitrogen	12
Liquid Nitrogen Cylinder	14
Operating	16
Controller Power Up	16
Heating Only Operation	17
Cooling Operation	18
Safety Information	19
Performance Characteristics	19
THEORY OF OPERATION	24
Functional Description	24
High Limit Controller	26
Watlow 982 Controller	27
Digital Communication	28
Serial Data Transmission	30
RS-232 Interface (Male) DTE (Computer, Terminal)	31
RS-530 Interface (Male) DTE (Computer, Terminal)	32
Accessory Cabling and Connectors	33
MAINTENANCE	35
Preventative Maintenance Schedule	37
Test Equipment Required	38
Chamber	38
Coolant Solenoid Orifice Assembly	39
CO ₂ Filter	40
Corrective Maintenance	41
Service Procedures	43
Main Blower Motor	43
Electronic Control Chassis	44

HI-LIMIT Thermoswitch	45
APPENDIX	46
IEEE 488 Interface Converter Set-up	46
IEEE 488 Interface Converter	48
RS-232/RS-422 Signal Level Selection	48
Serial Signal Descriptions	49
XON/XOFF Protocol	51
XON/XOFF Versus RTS/CTS Handshaking	51
Sample Program	52
Sample Output	53
Troubleshooting	54
Bill of Materials	55
Schematic Diagrams	56

INTRODUCTION

The Despatch Industries 900 Series Environmental Bench Chambers are designed for high performance and close temperature tolerance. A closed air flow system transfers heat to or from objects under test. The chamber is heated by a low-inertia coil heater and cooled by the injection and evaporation of a liquefied gas. An advanced control system holds chamber temperature to close tolerance.

Units are ideal for small lot qualification testing, burn-in, life test, temperature cycling or research and development. All models may be easily modified to add access ports, fixturing, instrumentation, etc., to meet special customer needs. All models are designed for continuous use with ease of operation and maintenance in mind.

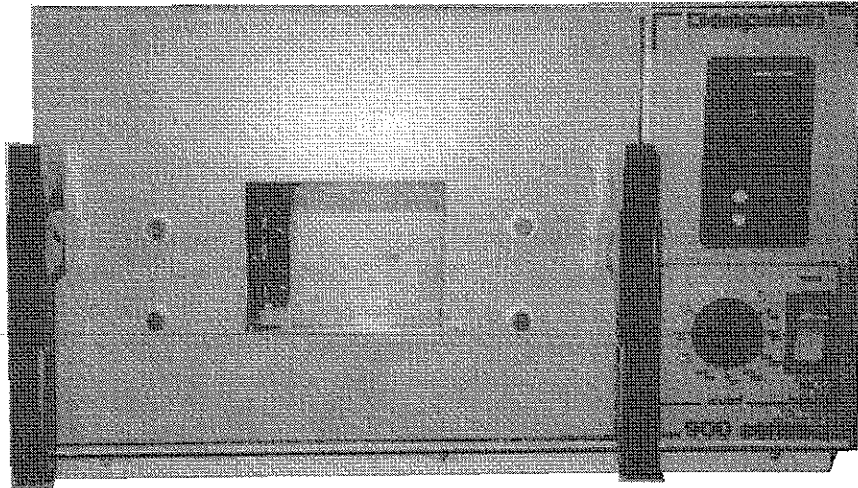

Figure 1. 900 Series Environmental Chamber Bench Oven

230 Volt, 50/60 HZ Operation

All 920 and 930 series units are designed for 115 volt, 50/60 Hz. operation. An optional transformer kit is available to allow these units to be used on 230 volt power supply.

Specifications

Model	924	934	925	935	926	936
Test Volume	0.4 ft ³ 0.01 m ³		0.78 ft ³ 0.02 m ³		0.78 ft ³ 0.02 m ³	
Workspace Dimensions inches (cm)						
Height	7 (18)		8.5 (22)		11 (28)	
Width	10 (25)		14.5 (37)		20 (15)	
Depth	10 (25)		11 (28)		14 (35)	
Exterior Dimensions inches (cm)						
Height	11 (28)		19.5 (50)		15.5 (39)	
Width	17.5 (44)		17.5 (44)		35 (89)	
Depth	18.5 (47)		19 (48)		24.5 (62)	
Temperature Range	<u>924D, 925D, 926D</u>			<u>934D, 935D, 936D</u>		
°F	-100 to + 525			-300. to +392		
°C	-73.3 to +274			-184 to +200		
Average Heat-up Rate, °/min	°F 72 °C 40		32 18		20 11	
Average Cool-down Rate, °/min	°F 46 °C 26	54 30	27 15	40 22	41 23	29 16
Temperature Control ₂	°F 0.25 °C 0.14	0.25 0.14	0.25 0.14	0.25 0.14	0.25 0.14	0.25 0.14
Live Load Capacity ₂	Watts 500		700		1000	
Temperature °F	85	200	85	200	85	200
°C	65	93	65	93	65	93
Heater Capacity in KW	2	2	2	2	2	2
Power Draw in Amps (120V-1ph-60Hz)	18.5	23	19.5	24	19.5	24
Air Flow	Horizontal 50 CFM		Vertical 150 CFM		Horizontal 175 CFM	
Approximate Weight	lbs 38 Kg 17	41 19	58 26	61 28	102 47	108 49

¹ Supply air temperature change rates over entire temperature range with chamber empty.
² At steady state conditions.

INSTRUCTIONS

Operator Training Requirements

All users must be thoroughly trained under the supervision of experienced personnel. The operator must aware of the danger of:

- suffocation from nitrogen and carbon dioxide gases,
- frostbite from nitrogen or carbon dioxide as liquid or frozen gases,
- fire.

User(s) must demonstrate an understanding of the equipment and its operation to assure knowledge of and practice of safe and proper operating procedures.

User(s) should receive regular re-training and testing as required to maintain a high level of proficiency and effectiveness.

Training should include the:

- function of controls and safety devices,
- handling of special atmospheres (on units with LN2 or CO2 auxiliary cool).

Installation

1. Remove all packing materials.
2. Inspect the oven for damage of any kind that could have occurred during shipment.
 - See whether the carton and plastic cover sheet inside carton are still in good condition.

- Look at all outside surfaces and corners of the oven for scratches and dents.

- Check the oven controls and indicators for normal movement, bent shafts, cracks, chips, and missing parts such as knobs and lenses.

NOTE:

Always refer to the electrical schematic for exact instructions on your equipment.

- Look inside the control cabinet for loose or broken parts.
- Open the chamber door and look at all the chamber surfaces to see that they are flat and smooth.

- Check the door and latch for smooth operation.

3. If anything is found to be out of order, check the rest of the oven very carefully for any other damage that could have occurred.

- a. If there is damage that could have happened during shipment, contact the shipper immediately and file a formal, written damage claim.

NOTE:

DO NOT install in wet, corrosive or explosive atmospheres.

- b. After you have filed a written damage claim with the shipper, contact Despatch Industries to report your findings and to order replacement parts for those that were damaged or missing. Please send a copy of your filed damage claim to Despatch.

4. Set the unit on a level floor with clearances of at least 6 inches on all ventilated sides.

5. Locate utility connections at the rear of the chamber.

6. Install the power cord.

The 920 series units are equipped with a 20 amp, 120 volt rated plug designed to be plugged into a Hubbell Model 5362, or equal, receptacle. This plug is required by the NEC and will provide necessary protection for this chamber installation.

The 930 series are equipped with a 30 amp, 120 volt rated plug designed to be plugged into a Hubbell Model 9308, or equal receptacle. This plug is required by the NEC and will provide necessary protection for this chamber installation.

WARNING:
If your receptacle cannot accommodate these plugs, your wiring and/or receptacle must be upgraded to allow this plug to be used. If the plug is modified, this equipment will not meet code and could result in a wiring and/or receptacle overload. Failure to heed this warning can result in wiring and/or receptacle overheating, fire and/or property damage, personal injury or death.

7. Connect the appropriate LN₂ or CO₂ supply to the fittings provided on the chamber.

8. CO₂/LN₂ Venting. The room must be ventilated sufficiently to ensure that the **oxygen level** in the vicinity of the chamber will be maintained **above 18%** and the **CO₂ level** will be maintained **below 1/2%** at the expected N₂ or CO₂ usage levels. If critical ventilation cannot be maintained, the exhaust port must be connected to an exhaust system which will vent the nitrogen or CO₂ out of the facility. The exhaust port is on the rear of the unit. NOTE: exhaust temperature may reach as high as 150°C (300°F).

CO₂/LN₂ consumption estimates are listed in the section titled "Performance Characteristics".

Installation of Cooling Gas

If the test chamber is to be cooled below chamber ambient temperature, it is necessary to provide a source of liquefied coolant gas. The type, quality, and handling of the gas is quite important as is the plumbing used to deliver the gas to the test chamber. Most test chamber operational problems are caused by improper gas use; thus, the installation procedures and precautions should be reviewed carefully before operating the chamber.

The liquid coolant gases should be used only after observing stringent safety considerations and practices.

Nitrogen is a non-toxic gas, but it can cause asphyxiation in a confined area that does not have adequate ventilation. Any atmosphere which does not contain enough oxygen for breathing (at least 18%) can cause dizziness, unconsciousness, or even death. Carbon dioxide affects the important acid-base balance within the body; the body can tolerate increased amounts of carbon dioxide only in limited

concentration. This is recognized in OSHA standards where a Threshold Limit Value of 5,000 parts per million by volume (0.5% concentration) has been adopted. For safety, concentrations above this level should not be permitted; increased concentrations can cause bodily harm or death.

Nitrogen and carbon dioxide cannot be detected by the human senses and will be inhaled like air. If adequate ventilation is not provided, these gases may displace normal air without warning that a life-depriving atmosphere is developing. Store containers outdoors or in other well-ventilated areas. Never enter any confined area where these gases may be present until the area is purged with air and is checked for a breathable atmosphere.

Never use containers, equipment, or replacement parts other than those specifically designated for use in nitrogen or carbon dioxide service. Gaseous nitrogen or carbon dioxide should be released only in an outdoor open area if disposal is required. Liquid nitrogen or carbon dioxide should be dumped into an outdoor pit filled with clean, grease-free and oil-free gravel, where they will evaporate rapidly and safely.

WARNING:

Nitrogen and carbon dioxide gases can cause asphyxiation and death if used in confined, poorly-ventilated areas.

Nitrogen and carbon dioxide as liquid or cold gases can cause freeze burns of the eyes and skin.

Installation of Carbon Dioxide

Before purchasing or installing CO₂ gas supplies, insure that the test chamber is the correct model to use CO₂ (High - 70 Kg/cm² or 1,000 PSI or Low - 21 Kg/cm² or 300 PSI) and that the desired low temperature can be reached by use of this gas. The following special CO₂ requirements must be met:

- The liquid CO₂ should be furnished by a reputable source.
- The liquid CO₂ cylinder must be a siphon-type. Siphon tank will have a red neck.
- The interior of the cylinder must be clean and absolutely dry before being filled by the supplier.
- Use of welding grade CO₂ offers no assurance of trouble-free operation. The internal condition of the cylinder and its previous use are more important than the quality of the CO₂.
- Never fully exhaust the cylinder after use or leave a cylinder which is to be returned to the supplier with the valve open. This will permit moisture or other contaminants to enter the cylinder and cause serious problems when the cylinder is reused later. If a cylinder is returned to the supplier without a positive pressure, it must be purged with dry nitrogen by the supplier before filling.

Other important factors are as follows:

- The interior of the liquid CO₂ pipe, tubing, hose and fittings used between the supply cylinder and the solenoid input valve of the temperature chamber must be kept clean and free of moisture at all times. Any moisture will turn to ice as the liquid CO₂ flows through the lines; the ice can then lodge on the solenoid valve seat or plug the orifice of the valve and cause system malfunction.
- Any low-pressure CO₂ connecting hoses between the supply cylinder(s) and the chamber input valve should be kept as short as possible and should be insulated.
- If the connecting hose is removed often or has been stored for a period of time, the line and fittings must be examined for presence of chips, rust or any foreign substance which can jam the inlet valve or plug the valve orifice.

- A filter installed in the line must be checked for cleanliness every 50 hours of operation, or more often if necessary. Clean the filter in trichloroethylene and dry thoroughly using filtered, moisture-free compressed air at low pressure.

It is important that the CO₂ solenoid valve assembly and the orifice be kept clean.

Additional Precautions

- Never install CO₂ supply pipe fittings or valves of a larger internal diameter than those used upstream [beginning at the supply cylinder(s)].
- Do not use fittings which allow undue expansion or restriction of the liquid CO₂. This could cause the CO₂ to reach a critical point where it would expand in the line and cause icing.
- Do not use excessively long, small diameter supply hoses which might cause the liquid to change to gas in hot areas or during intermittent cycling conditions.
- Do not meter the CO₂ through any type of valve that has a smaller I.D. than the supply hose and CO₂ supply cylinder siphon tube. The cylinder supply valve should be fully open during use.
- It is not possible to use all of the CO₂ in a siphon-type cylinder. The ambient temperature at the cylinder will determine the amount of CO₂ available (about 95 percent of maximum). Thus, CO₂ usage may appear to be somewhat higher than it actually is.
- Never set the temperature controller below -100 °F (-73 °C). Excessive snowing occurs as you approach temperature below -100 °F (-73 °C) until the temperature reaches -109 °F (-78 °C) which is the freezing point of CO₂ at atmospheric pressure. At -109 °F (-78 °C) all discharged CO₂ could form snow which could cause damage to the chamber and its contents and if allowed to build up to the point of blocking off the pressure relief vent, could cause explosion of the chamber due to available pressure from the liquid carbon dioxide source.

Pressure of Solid, Liquid and Saturated Vapor CO₂

Temperature (°F)	Pressure (PSIA)	Temperature (°F)	Pressure (PSIA)
-140	3.19	-20	215.02
-130	5.39	-10	257.46
-120	8.85	0	305.76
-110	14.22	+10	360.4
-100	22.34	20	421.8
-90	34.05	30	490.6
-80	50.70	40	567.3
-70	74.90	50	652.7
-69.9	75.1 (triple point)	60	747.4
-60	94.75	70	852.5
-50	118.27	80	969.3
-40	145.87	87.8	1072.1
-30	177.97		

- The solenoid valve used to inject the CO₂ coolant into the test chamber should "pulse" or actuate rapidly. If the CO₂ valve remains open for long periods of time after pull-down, the chamber may be leaking coolant, the test object may be introducing substantial amounts of heat beyond the capacity of the inlet valve orifice, or the temperature set-point may be set below -73.3 °C (-100 °F). These conditions can cause "snow" to be introduced into the chamber with resultant control problems and possible damage to the chamber and contents. Causes for these conditions should be located and corrected.

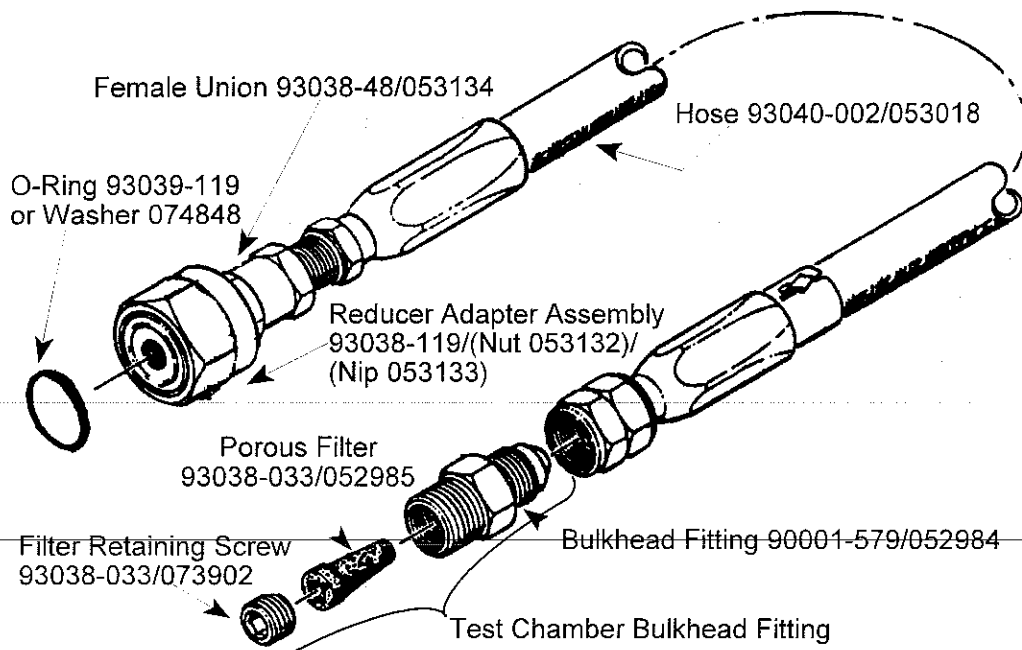

Figure 2. Filter Cleaning -Typical CO₂ Reducer-Adapter Assembly

Liquid CO₂ Cylinder Installation

For extensive use at low temperatures, it is recommended that two or more liquid CO₂ cylinders be used in parallel.

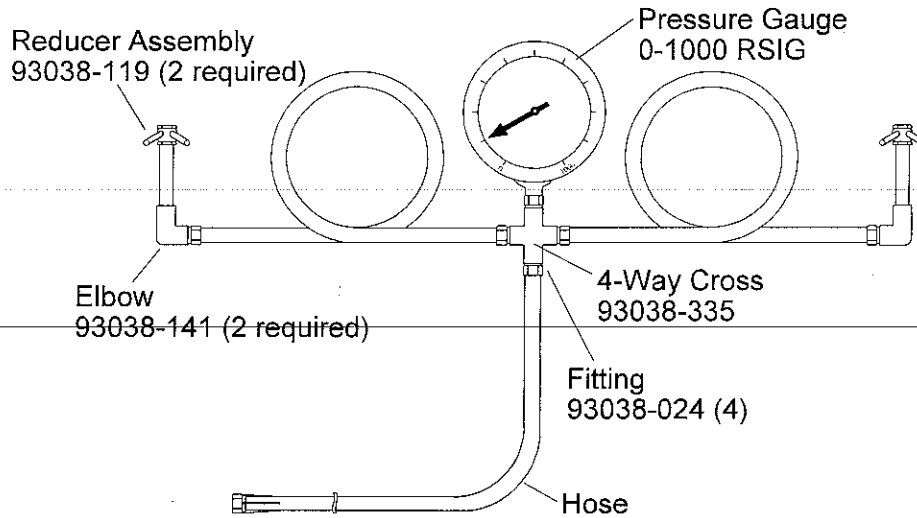

Figure 3. Connections of High or Low Pressure CO₂ sources

This will increase operating time between cylinder changes. Install the liquid CO₂ cylinder(s) as follows.

1. Turn off POWER switch and disconnect AC input power.
2. Position the cylinder in a safe and convenient location.
3. Secure the cylinder in an upright position with safety chains.
4. Carefully crack the cylinder valve slightly before connecting the hose assembly in order to blow out any loose scale or rust which may be in the cylinder.
5. Connect the hand wheel end of the hose assembly to the cylinder.
6. Connect the threaded fitting on the flexible hose to the threaded portion on the chamber bulkhead fitting. The bulkhead fitting must be held in place with a second wrench while the coolant hose is being attached.
7. When replacing the CO₂ cylinder,

WARNING:
Always use heavy safety chains to hold gas cylinders securely in an upright position. A gas cylinder, damaged by hitting the floor, can become a dangerous projectile and cause serious damage or injury over a wide area.

- a. Shut off chamber if controls call for cool (see LED L2 on the front panel).
 - b. Shut off the valve at the cylinder.
 - c. Crack the hose fitting slightly, and allow the residual CO₂ pressure in the hose to bleed off before disconnecting the hose.
 - d. Connect hose to new cylinder.
 - e. Open cylinder valve.
 - f. "Crack" the fitting at the bulkhead to bleed off gas and moisture.
 - g. Turn chamber on.
-

Installation of Liquid Nitrogen

Some models of test chambers use pressurized liquid nitrogen (LN₂) so that lower test temperatures may be reached. Line pressure should be between 55 kPa (8 PSI) and 310 kPa (45 PSI).

- The following precautions should be observed in handling LN₂ :
- Liquid nitrogen is extremely cold (-196 °C or -320 °F) at atmospheric pressure and can damage skin or eyes on contact.
- Insulated gloves and safety goggles or face plates should always be used in handling LN₂.
- Clean cotton clothes or lab coats should be worn where LN₂ spillage or prolonged contact with its vapors is a factor.
- Smoking should be prohibited in the immediate area where LN₂ is being handled.
- All handling equipment such as funnels, dewars, piping and tubing must be clean, dry and free of grease.
- All transfer tubes, valves and other equipment which reach liquid nitrogen temperatures should be properly insulated with a non-absorbent insulation which is properly contained within a vapor seal.

- Liquid nitrogen is not in itself explosive or combustible; however, its low temperature will cause condensation of the water vapor in the air and all the gaseous constituents of the air which liquify above $-196\text{ }^{\circ}\text{C}$ ($-320\text{ }^{\circ}\text{F}$), including oxygen. Therefore, supply lines, clothes and equipment which are subject to this temperature can absorb or liquify oxygen, which will cause a severe fire if ignited and which can become explosive when in contact with grease.
- LN_2 should not be left in sealed containers or hoses. When the LN_2 turns to nitrogen gas, it will build up very high pressure. Unless LN_2 is being actively used in test chamber operations, care should be taken that an adequate vent is provided and that excessive pressure is bled off.
- The concentration of liquid oxygen suspended in the LN_2 builds up as the LN_2 is used. Consequently, nearly empty LN_2 containers should be handled as if they were liquid oxygen containers. The presence of liquid oxygen in LN_2 can be determined by the milky appearance of the liquid. LN_2 is normally clear.
- If parts of the body are frozen by contact with these cold liquids, first-aid treatment for frostbite should be given, with slow thawing of the frozen parts. Severe cases should be referred to a physician for treatment.

Liquid Nitrogen Cylinder

The liquid nitrogen cylinder is connected to the test chamber by the hose assembly.

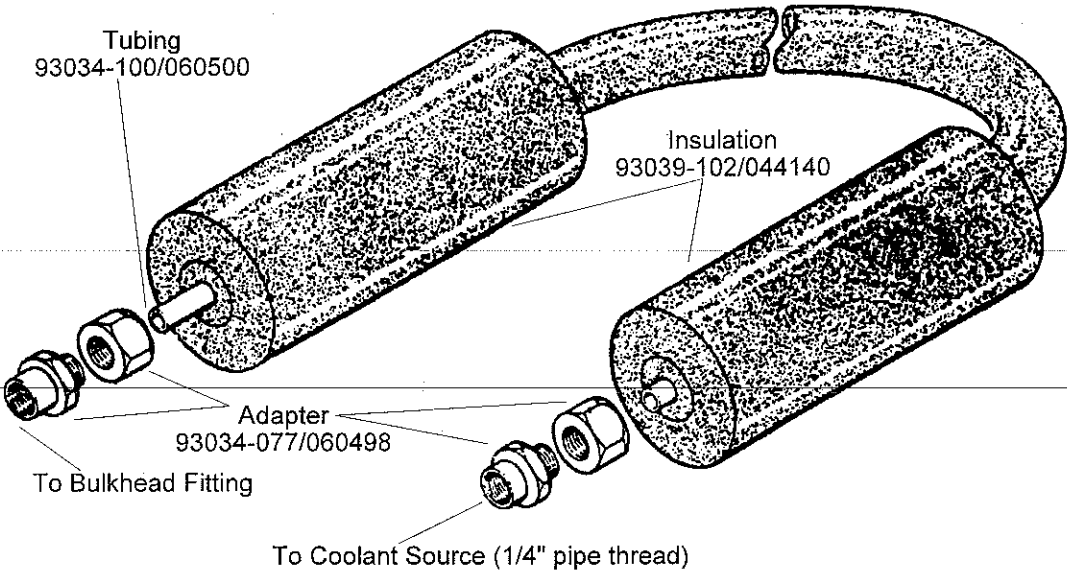

Figure 4. Liquid Nitrogen Hose Assembly

To prevent ice crystals in the coolant line from entering the test chamber, an ice filter (optional) may be connected between the LN₂ cylinder and the test chamber.

NOTE:
Slide the insulation over the fittings after connecting to the bulkhead fitting and the coolant source.

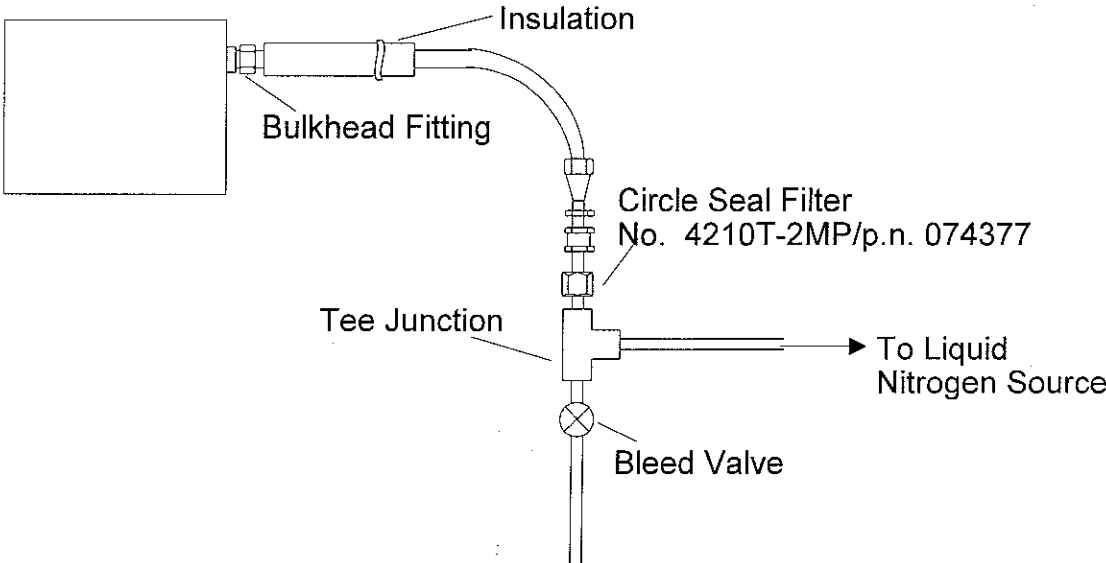

Figure 5. Recommended Liquid Nitrogen Ice Filler

The ice filter eliminates ice crystals and prevents them from freezing up valves or intruding into the test chamber. The ice filter should be cleaned periodically by a reverse purge using dry nitrogen. Install the LN₂ cylinder as follows.

1. Turn off POWER switch and disconnect AC power.
2. Position the cylinder in a safe and convenient location.
3. Connect the cylinder to the test chamber as indicated. The large foam insulation sleeves (item 3) are pushed over the fitting after the connections have been made.
4. Use a second wrench to prevent the bulkhead fitting from turning when the connection is being tightened.

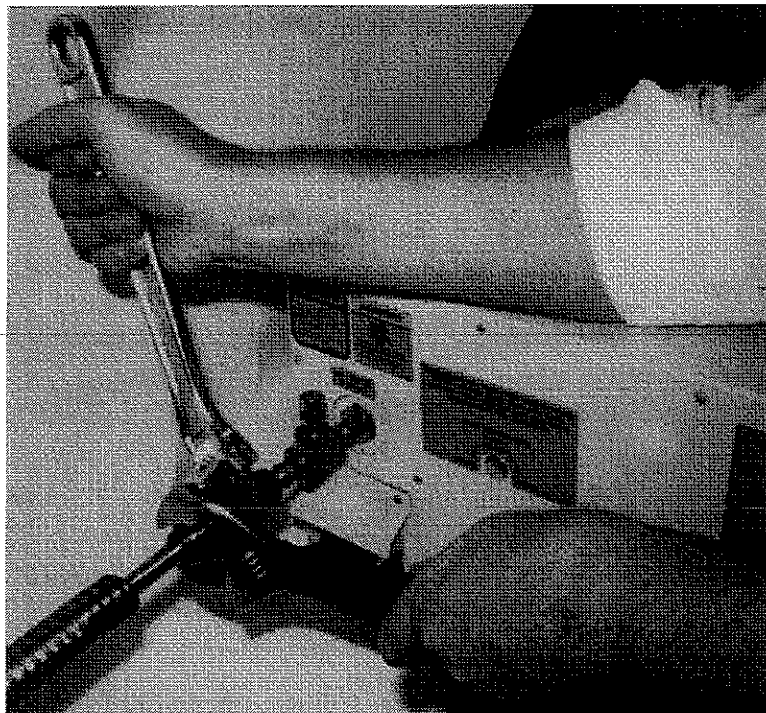

Figure 6 illustrates the liquid nitrogen connection being tightened.

WARNING:
Store and use liquid nitrogen only in a well-ventilated area.

Operating

Users and operators of this oven must comply with operating procedures and training of operating personnel as required by the Occupational Safety and Health Act (OSHA) of 1970, Section 5 and relevant safety standards, and other safety rules and regulations of state and local governments. Refer to the relevant safety standards in OSHA and National Fire Protection Association (NFPA), Section 86 of 1990.

WARNING:
Do not use oven in wet, corrosive or explosive atmospheres unless this oven is specifically designed for a special atmosphere.

Chamber temperature is set and maintained by the control panel and control circuitry. This combination results in a constant, controlled, manually-selected chamber temperature. In addition, a Despatch Watlow 982 controller can be programmed to obtain a series of preset temperatures and time durations. Also available are computer interface buss accessories which allow the chamber to be controlled from a host computer.

In the event of a controller malfunction, the chamber and test object are protected from excessive temperatures by two overtemperature safety thermostats. One of the overtemperature thermostats is adjustable and is located on the front panel of the chamber. The other overtemperature thermostat is factory calibrated and is mounted behind the chamber rear panel.

Controller Power Up

Power to the controller is supplied through the chamber. The HEAT and COOL lights (LEDs L1 and L2) will come on and the controller will immediately begin to reach the setpoint temperature when the chamber POWER switch is turned on.

Heating Only Operation

For heating only applications, when the chamber is heated only above chamber ambient, cooling gas supplies and plumbing are not needed. Operation of the chamber then requires setting the temperature control and overtemperature safety set-points. If the Watlow 982 is used, refer to the controller instructions section included with these options.

WARNING:

Avoid adapters that will either unground the chamber or will permit connection to the wrong power source. Check the current rating of the circuit.

1. Attach the test fixture or tray to the chamber.
2. Insure that the POWER switch is off.
3. Plug the chamber power cord to the correct line power receptacle. (See Power Cord Installation)
4. Set the HI-LIMIT control to a temperature that is higher than the desired chamber temperature but lower than a temperature at which the test object might be damaged.
5. Toggle the POWER switch ON and allow the chamber to heat to the correct operating temperature.
6. Set the SET-POINT control to the desired temperature.
7. Overtemperature thermostat function should be verified each time the chamber is started.
 - a. Verify proper function of overtemperature thermostat by adjusting its setpoint lower than the chamber temperature. Power should be cut off to the heater(s) and fan motor(s).
 - b. An overtemperature trip or power outage requires manual reset by placing power switch to reset position.

Should a controller malfunction occur and the test chamber reaches the adjustable overtemperature set point, the overtemperature thermostat will automatically cut off the line power to the heaters.

Cooling Operation

Cooling operations with the chamber are essentially the same as those for heating operations. If the Watlow 982 control is used, refer to the special instructions included with these options.

1. Attach the test fixture or tray to the chamber.
2. Insure that the POWER switch is off.
3. Connect LN₂ supply.
4. Turn on supply valve.
5. Plug in the chamber power cord to the correct line power. Avoid adapters that will either unground the chamber or will permit connecting to the wrong power source. Check current rating of circuit.
6. Turn the POWER switch ON and allow the chamber to cool to the correct operating temperature. The HI-LIMIT control is not used during cooling operations.
7. Set the SET-POINT to the desired temperature.

A relief port has been included in the chamber to protect against excessive internal pressure.

The cooling system will operate efficiently only when there is no vapor lock in the coolant line. Vapor locks can be reduced by keeping the coolant cylinders and lines at the same temperature or by preventing the coolant lines from passing through areas of much higher temperature. It is also a good practice to keep the coolant lines as short as possible.

When the chamber is not in use, or when it is used for other than low temperature tests, the valves of the coolant cylinder(s) should be closed to prevent leakage.

After long periods of operation at low temperatures, a certain amount of moisture condenses inside the chamber in the form of snow and frost. Although the insulation in the test chamber is sealed against both internal and external accumulation of moisture, some moisture will eventually collect in the fiberglass insulation. The resulting loss in insulation efficiency tends to decrease cooling rate and increase coolant consumption.

To avoid moisture collection in the insulation after sustained operation at low temperatures, the test chamber should be operated for at least one hour at 205 °C (400 °F) to evaporate the moisture. Do not exceed this temperature with the cryogenic models which are insulated with high-temperature-resistant polyurethane (isocyanate) foamed-in-place resin. This insulation will be damaged if temperatures in excess of 205 °C (400 °F) are sustained.

Safety Information

Operating and burst pressures for various hose assemblies are given in the following table.

Component	Operating Pressure		Burst Pressure	
	kPa ²	PSI	kPa ²	PSI
CO ₂	20685	3000	68950	10000
LN ₂	310	45	2586	375

Performance Characteristics

The following tables list the performance characteristics for the test chambers. The tables are used topically as follows.

1. Find approximate temperature of test chamber in left-hand column.
2. Find temperature desired in second column from left.
3. Determine the CO₂ consumption from the right-hand column under CO₂ CONSUMPTION.
 - Column AIR lists the amount of CO₂ needed to bring the air temperature in the test chamber to the desired degree.
 - The AIR + WALLS column lists the associated amount of CO₂ needed to bring the air and the chamber walls to the desired temperature.
 - Column RATE/HOUR lists the hourly rate of CO₂ consumption needed to maintain the low temperature.
 - The CO₂ consumption in minutes may vary depending on the heat dissipated by the size and material of the test object.

4. Find the minutes needed to reach the desired temperature in the middle columns under MINUTES NEEDED TO REACH TEMPERATURE.

- Column AIR lists the time required for the air in the chamber to reach the selected temperature.
- The AIR + WALLS column lists the associated total time required for the air and walls to reach the selected temperature.

The data in the table for the appropriate test chamber model can be plotted for the temperature changes of interest to better visualize the chamber performance and to interpolate intermediate values.

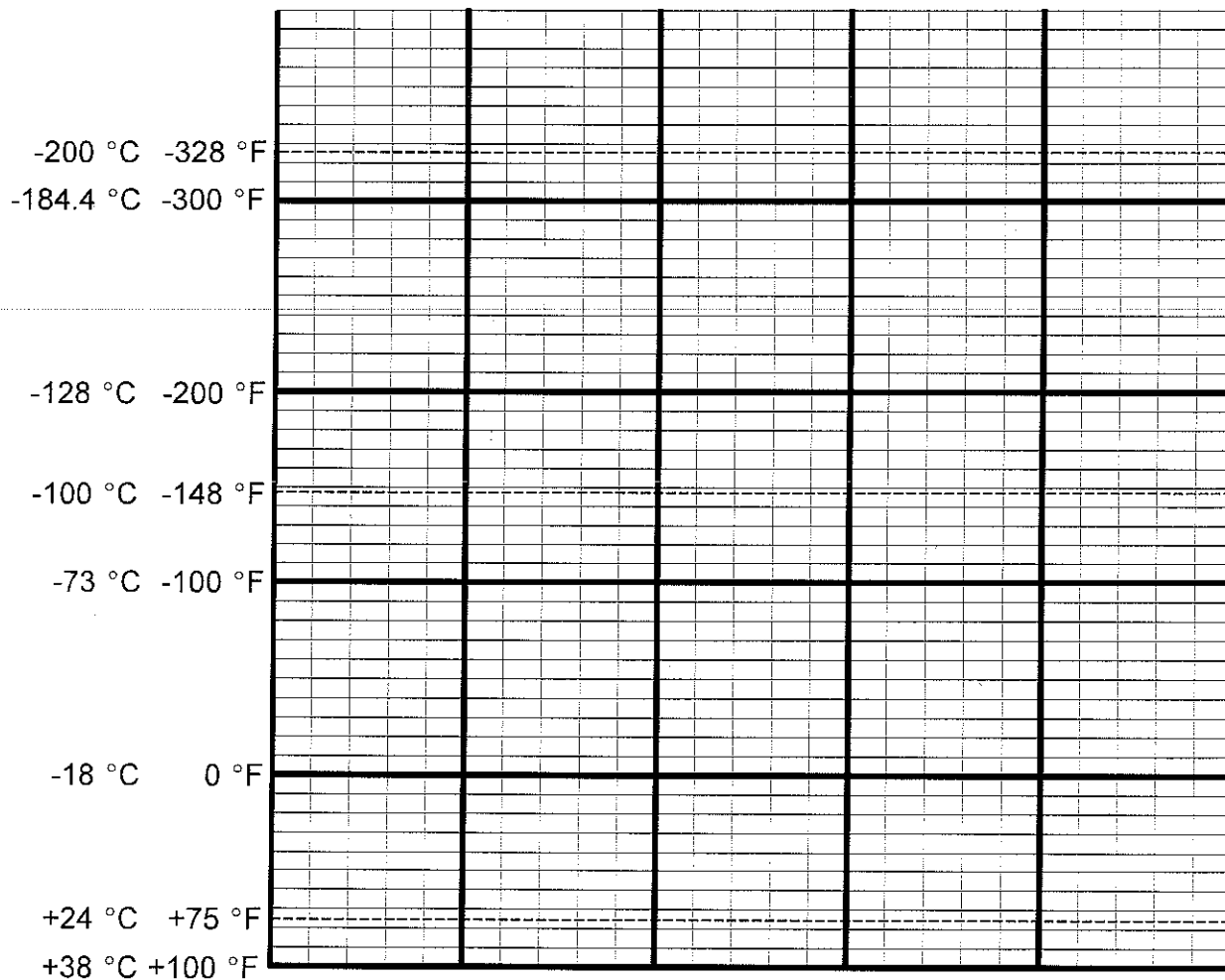

Figure 7. Performance Curve Plotting Blank

Performance Characteristics, Model 925

Temp. Set Points		Minutes Needed to Reach Temp.		CO ₂ Consumption in Pounds (900 psi)		
°C	To	Air	Air + Walls	Air	Air + Walls	Rate/Hr.
+24 to -73	+75 to -100	4.0	13.0	5.0	5.5	8.5
+24 to -45	+75 to -50	3.0	8.0	3.0	3.5	8.0
+24 to -18	+75 to 0	.50	7.0	1.5	2.5	6.0
+24 to +38	+75 to +100	.75	5.0	--	--	--
+24 to +93	+75 to +200	4.5	13.0	--	--	--
+24 to +149	+75 to +300	9.0	18.0	--	--	--
+24 to +204	+75 to +400	13.0	23.0	--	--	--
+24 to +260	+75 to +500	17.0	27.0	--	--	--
+71 to -73	+160 to -100	7.0	12.0	7.0	7.5	8.5
+71 to -45	+160 to -50	6.0	10.0	5.0	6.0	8.0
+71 to -18	+160 to 0	5.0	10.0	4.0	5.0	6.0
+93 to +24	+200 to +75	4.0	8.5	3.0	3.5	4.5
+149 to +24	+300 to +75	5.0	10.0	5.0	5.5	4.5
+204 to +24	+400 to +75	7.0	12.0	6.5	7.0	4.5
+260 to -59	+500 to -75	10.0	13.0	10.5	13.0	8.5
+260 to -73	+500 to -100	16.0	19.0	12.0	14.0	8.5
-73 to +24	-100 to +75	6.0	9.0	--	--	--
-73 to +260	-100 to +500	22.0	32.0	--	--	--

Performance Characteristics, Model 935

Temp. Set Points		Minutes Needed to Reach Temp.		LN ₂ Consumption in Pounds		
°C	°F	Air	Air + Walls	Air	Air + Walls	Rate/Hr. C
+24 to -18	+75 to 0	3.75	7.0	2.5	3.0	10.25
+24 to -45	+75 to -50	4.5	8.5	3.5	4.0	11.0
+24 to -73	+75 to -100	6.0	10.0	4.0	5.0	12.75
+24 to -100	+75 to -150	7.0	11.0	6.25	7.0	15.0
+24 to -129	+75 to -200	8.0	11.5	7.5	8.5	17.5
+24 to -150	+75 to -250	10.0	12.0	9.0	10.5	18.0
+24 to -184	+75 to -300	12.5	15.0	10.5	14.0	20.0
+24 to +38	+75 to +100	1.5	3.5	--	--	--
+24 to +93	+75 to +200	3.5	6.0	--	--	--
+24 to +149	+75 to +300	7.0	11.0	--	--	--
+24 to +204	+75 to +400	12.0	23.0	--	--	--
+93 to -73	+200 to -100	8.0	11.0	6.0	7.5	12.75
+93 to -129	+200 to -200	9.0	11.5	9.5	12.0	17.5
+93 to -184	+200 to -300	13.0	16.75	14.25	18.0	20.0
+93 to +24	+200 to +75	6.5	9.0	3.5	4.0	--
+204 to -129	+400 to -200	15.5	18.0	13.5	15.0	17.5
+204 to -184	+400 to -300	17.5	20.0	19.0	20.0	20.0
-184 to +24	-300 to +75	13.5	16.5	--	--	--
-184 to +204	-300 to +400	19.0	35.0	--	--	--

Performance Characteristics, Model 934

Temp. Set Points		Minutes Needed to Reach Temp.		LN ₂ Consumption in Pounds		
				Amount by Stages	Total	Rate/Hr
°C	°F	A (Air)	Air + Walls	A (Air)	Air + Walls	C
+24 to -18	+75 to 0	2.0	0.9	0.25	0.75	6.25
+24 to -45	+75 to -50	4.5	11.0	1.75	2.5	7.5
+24 to -73	+75 to -100	5.0	12.0	2.25	3	8
+24 to -100	+75 to -150	6.5	13.0	2.75	4	9.75
+24 to -129	+75 to -200	7.0	14.0	4	4.75	10.75
+24 to -150	+75 to -250	8.0	14.5	5	6.25	12
+24 to -184	+75 to -300	8.5	15.0	5.5	6.5	13
+24 to +38	+75 to +100	1.0	4.5	--	--	--
+24 to +93	+75 to +200	3.5	16.0	--	--	--
+24 to +149	+75 to +300	10.0	30.0	--	--	--
+24 to +204	+75 to +400	12.0	41.0	--	--	--
+93 to -73	+200 to -100	6.0	19.0	1.75	3.75	8
+93 to -129	+200 to -200	8.0	22.0	3.5	5.75	10.75
+93 to -184	+200 to -300	9.0	23.0	5.5	9	13
+93 to +24	+200 to +75	2.5	10.0	0.75	1	--
+204 to -129	+400 to -200	11.0	24.0	7	10	10.75
+204 to -184	+400 to -300	13.0	26.0	8	11	13
-184 to +24	-300 to +75	3.5	13.0	--	--	--
-184 to +204	-300 to +400	8.0	50.0	--	--	--

Performance Characteristics, Model 924

Temp. Set Points		Minutes Needed to Reach Temp.		CO ₂ Consumption in Pounds (900 psi)		
				Amount by Stages	Total	Rate/Hr.
°C	°F	A (Air)	Air + Walls	A (Air)	Air + Walls	C
+24 to -73	+75 to -100	4.0	11.0	2.4	3.8	5.0
+24 to -45	+75 to -50	2.0	8.0	1.9	2.8	4.5
+24 to -18	+75 to 0	1.0	5.0	1.4	2.7	4.0
+24 to +38	+75 to +100	0.5	3.0	--	--	--
+24 to +93	+75 to +200	2.0	12.0	--	--	--
+24 to +149	+75 to +300	5.0	22.0	--	--	--
+24 to +204	+75 to +400	8.0	26.0	--	--	--
+24 to +260	+75 to +500	12.0	32.0	--	--	--
+71 to -73	+160 to -100	6.0	21.0	3.6	6.4	5.0
+71 to -45	+160 to -50	4.0	14.0	2.2	4.2	4.5
+71 to -18	+160 to 0	2.0	8.0	1.8	2.1	4.0
+93 to +24	+200 to +75	2.0	11.0	1.1	1.4	--
+149 to +24	+300 to +75	3.0	18.0	2.2	3.1	--
+204 to +24	+400 to +75	5.0	38.0	3.0	4.5	--
+260 to -59	+500 to -75	7.0	52.0	4.0	6.7	--
+260 to -73	+500 to -100	12.0	67.0	8.3	10.5	5.0
-73 to +24	-100 to +75	3.0	8.0	--	--	--
-73 to +260	-100 to +500	20.0	45.0	--	--	--

Performance Characteristics, Model 936

Temp. Set Points		Minutes Needed to Reach Temp.		LN ₂ Consumption in Pounds		
				Amount by Stages	Total	Rate/Hr.
°C	°F	A (Air)	Air + Walls	A (Air)	Air + Walls	C
+24 to -18	+75 to 0	3.0	12.0	1.75	3	5.25
+24 to -45	+75 to -50	5.0	13.5	3.25	5.25	8.75
+24 to -73	+75 to -100	6.0	16.0	5	7.5	12.25
+24 to -100	+75 to -150	7.5	18.0	7	9.75	15.5
+24 to -129	+75 to -200	8.0	20.0	8.5	12	18.75
+24 to -150	+75 to -250	10.0	22.0	10.74	15.25	22.25
+24 to -184	+75 to -300	12.0	24.0	13	18	25.75
+24 to +38	+75 to +100	1.5	9.0	--	--	--
+24 to +93	+75 to +200	4.0	20.0	--	--	--
+24 to +149	+75 to +300	9.0	38.0	--	--	--
+24 to +204	+75 to +400	16.0	53.0	--	--	--
+93 to -73	+200 to -100	10.0	26.0	6.5	11	12.25
+93 to -129	+200 to -200	15.0	31.0	13	19	18.75
+93 to -184	+200 to -300	18.0	36.0	19	26.25	25.75
+93 to +24	+200 to +75	7.0	19.0	2.25	3.25	--
+204 to -129	+400 to -200	18.0	47.0	17.5	26	18.75
+204 to -184	+400 to -300	22.0	50.0	22	33	25.75
-184 to +24	-300 to +75	13.0	22.0	--	--	--
-184 to +204	-300 to +400	28.0	65.0	--	--	--

Performance Characteristics, Model 926

Temp. Set Points		Minutes Needed to Reach Temp.		CO ₂ Consumption in Pounds (900 psi)		
				Amount by Stages	Total	Rate/Hr.
°C	°F	A (Air)	Air + Walls	A (Air)	Air + Walls	C
+24 to -73	+75 to -100	4.00	20.00	6.0	10.0	9.0
+24 to -45	+75 to -50	1.75	13.00	3.0	5.5	7.0
+24 to -18	+75 to 0	1.00	6.00	1.4	1.5	5.0
+24 to +38	+75 to +100	0.75	4.50	--	--	--
+24 to +93	+75 to +200	4.00	22.00	--	--	--
+24 to +149	+75 to +300	6.75	45.00	--	--	--
+24 to +204	+75 to +400	11.10	64.00	--	--	--
+24 to +260	+75 to +500	16.75	82.00	--	--	--
+71 to -73	+160 to -100	4.30	21.00	7.5	13.0	9.0
+71 to -45	+160 to -50	3.50	18.00	4.5	9.0	7.0
+71 to -18	+160 to 0	1.75	14.00	2.7	7.0	5.0
+93 to +24	+200 to +75	1.80	10.00	2.0	9.0	--
+149 to +24	+300 to +75	2.00	18.00	2.5	12.5	--
+204 to +24	+400 to +75	3.00	26.00	6.5	15.5	--
+260 to -59	+500 to -75	10.00	43.00	14.0	23.0	--
+260 to -73	+500 to -100	12.00	50.00	15.0	25.0	9.0
-73 to +24	-100 to +75	3.25	32.00	--	--	--
-73 to +260	-100 to +500	20.00	120.00	--	--	--

THEORY OF OPERATION

This section contains a functional as well as a detailed circuit description of the temperature control circuits in all models of these chambers.

Functional Description

The Despatch 900 Series Environmental Bench Chamber uses a closed airflow system to transfer heat to or from objects under test. A low inertia electric coil heater is used for elevated temperatures in the chamber. Cooling of the chamber is accomplished by injecting liquid carbon dioxide or liquid nitrogen into the test chamber, where the coolant rapidly evaporates. The operating temperature of the test chamber is determined by the setting of the Watlow 982 control.

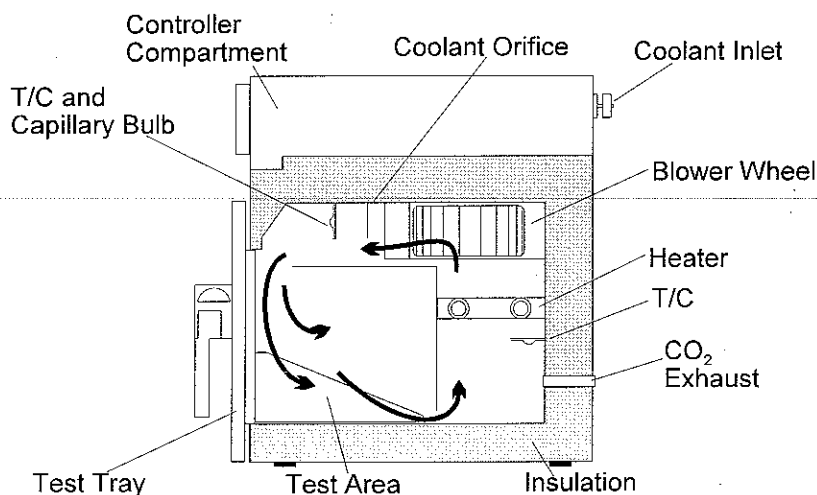

Figure 8. Model 925 and 935 Air Flow in Side View

Temperature sensing elements in the chamber allow the control to automatically maintain chamber temperature at the value indicated on the setpoint switches. A dual PID control loop in the Watlow 982 activates heating or cooling as necessary.

The dual output control ensures that only one function, heating or cooling, is in operation at any one time. This eliminates the possibility of the heat control circuit opposing the cool control circuit.

An overtemperature circuit protects the test chamber and test objects by removing power to heaters when the test chamber exceeds the maximum rating of the chamber (274 °C).

An adjustable high limit allows the maximum operating temperature to be selected or varied for each test. This dial type unit will interrupt the power to the heater if the chamber temperature exceeds the high limit setting.

The detailed description of the temperature control circuits is similar for all test chamber models; therefore, only the temperature control circuit for Model 924 is discussed in detail.

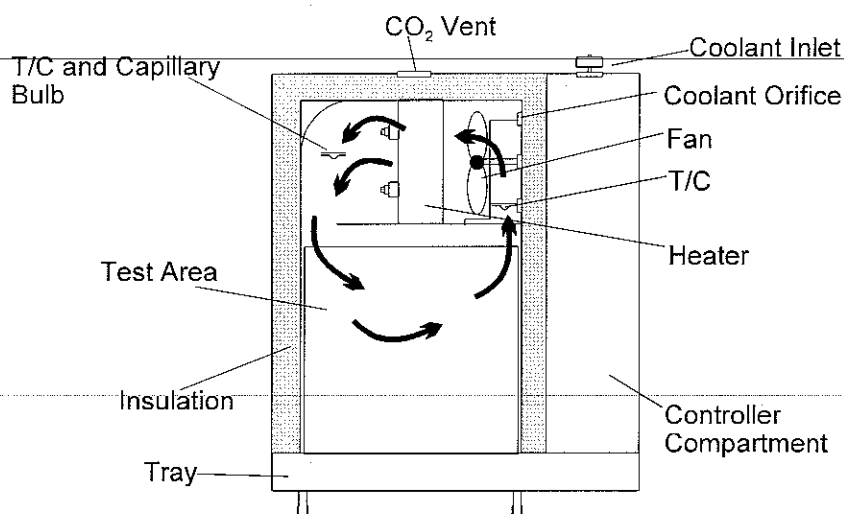

Figure 9. Model 934 and 924 Air Flow in Side View

Basically the same as in 936 and 926 which also have horizontal air flow.

Models 935, 934 and 936 use two additional heaters: HTR2 located under the opening gasket of the chamber and HTR3 located on the shaft bushing of motor B1. The 935 has an additional heater HTR4 located on the shaft bushing of the second motor B2. Heater HTR2 is controlled by thermoswitch S5, which is set at +10 °F ±5 °F.

The thermoswitch is located on the rear of the Transite liner and senses the door opening temperature of the liner and door opening frame assembly. The heaters prevent the test tray door from frosting excessively, the door seal from freezing at temperatures of -300 F. When the temperature test chamber is not being operated at extremely low temperatures, thermal switch S5 is open, disabling HTR2. A factory set thermoswitch limits the chamber to the maximum chamber operating temperature.

The line power to the heaters is interrupted. The power will restart automatically when the temperature is dropped below the overtemperature setpoint.

High Limit Controller

This chamber is equipped with a non-indicating high limit controller. Anytime the chamber temperature exceeds the limit set point, the control will trip, and conditioning will stop. Power will not be restored until the chamber temperature is within tolerance. Refer to the enclosed electrical schematic and the instrument instruction manual.

To reset the high limit controller after tripping, allow the chamber to cool below the high limit setpoint. Place the POWER switch to the RESET position and release.

The chamber may be equipped with an optional low limit temperature control. This is a non-latching control that will automatically reset once the chamber temperature has risen above the low limit setpoint. The low limit setpoint can be adjusted by changing the low temperature alarm setting on the Watlow 982 controller.

Watlow 982 Controller

After 1 minute with no key activations, the control reverts to the display loop. The process value appears in the upper display and the set point is in the lower display.

Keys and Displays	Description
Upper Display	Indicates either actual process value, the operating prompt values, or error codes. When powering up, the process display will be blank for 3 seconds.
Dev LED	When lit, the deviation from the current set point is shown in the lower display.
% Out LED	When lit, the current percent output is shown in the lower display.
▲ Key	Increases the value of the displayed prompt. A light touch increases the value by one. Holding the key down increases the value at a rapid rate. New data is self entering in 5 seconds or once the MODE key or DISPLAY key is pressed.
▼ Key	Decreases the value of the displayed prompt. A light touch decreases the value by one. Holding the key down decreases the displayed value at a rapid rate. New data is self entering in 5 seconds or once the MODE key or DISPLAY key is pressed.
▲ key and ▼ key	When pressed simultaneously for 3 seconds, the setup (SEt) prompt appears. Continue to press the ▲ key and the ▼ key for another 3 seconds and the factory (Fcty) prompt appears.
MODE Key	Steps the control through the menus. New data is entered once the MODE key is pressed.
MODE and ▲ key	To move backwards through the menus, hold ▼ key and the MODE key, then press the ▲ key to scroll. The MODE key must be pressed first and held before the ▲ key will begin scrolling. Scrolling is disabled once the keys are released or you reach the top of the menu.
Lower Display	Indicates the set point, deviation, percent power temperature unit, menu prompts, or alarm codes.
L1, L2, L3, L4	When lit, these LEDs indicate when Output #1, #2, #3 or #4 are active, respectively. Outputs on are configured as: Ot1 - Heat Control, Ot2 - Heat Control, Ot3 - Event or Alarm, Ot4 - Communications Flashes on transmit and receive.
DISPLAY Key	Pressing this key enters the display loop. The DISPLAY key can be pressed at any time to return to this loop. For more information on the display loop, see the next page.
HOLD/RUN Key	Pressed once, it clears a latched alarm without altering the Hold/Run status.
HOLD/RUN LED	Lit when the control is running. When blinking, press the HOLD/RUN key again to begin running.

Digital Communication

Digital communication is available in one of three formats:

- RS-232 (available on Models 982A-_____-R__ and 982A-_____-U__)
- RS-485 (available on Models 982A-_____-S__ and 982A-_____-U__)
- RS-422 (available only on Models 982A-_____-S__)

RS-232 is a common, unbalanced communication configuration. It is the type of communication supported by the typical COM1 and COM2 hardware of a standard PC. There are three main wires (negative transmit, negative receive, common). Some devices use other handshaking protocol wires (RTS, CTS, etc.), but Watlow controls do not.

RS-485 is a balanced communication configuration. This means that the transmit and receive lines are in pairs. Typical wiring is two wire: negative transmit/receive, and positive transmit/receive. Some instruments also have a common. The Watlow controls do have a common.

RS-485 supports up to 32 devices without repeaters. Since there is only one pair of wires, a control cannot listen and talk at the same time. Listen or talk state must be selected by either handshaking hardware or signal driven handshaking. The Watlow controls use signal driven listen/talk state enable. They are in listen state unless addressed by a master. See the Watlow manual information on the communication protocol for multiple devices. The RS-485 single pair wiring allows any or more than one device to be the master.

RS-422 is also a balanced communication configuration. The voltage levels and the balanced pair wiring are so similar to RS-485 that they are sometimes used interchangeably. However, RS-422 is typically four wire and has separate (positive transmit, negative transmit, positive receive, negative receive) pairs. (Again, the Watlow controls also have a common.) The dual pairs mean that any device can be both listening and talking at the same time.

With RS-422, only one device can be the master since all the slave transmit pairs are wired to the master's receive, and all slave receive pairs to the master's transmit. This also means that no slave can listen or talk to another slave device which, in some cases, can be good.

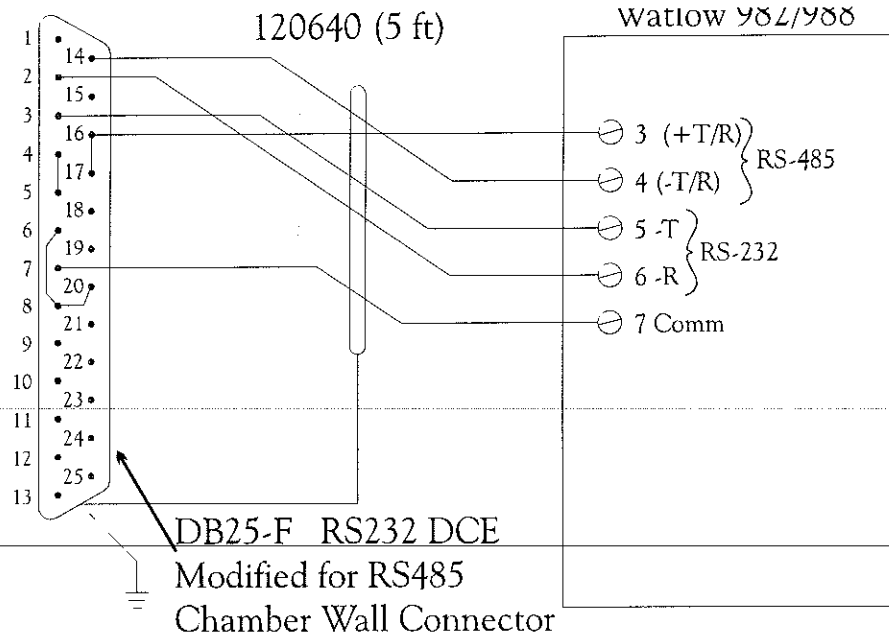

Figure 10. Optional W982/986 Communications Cable Connection
RS232/485

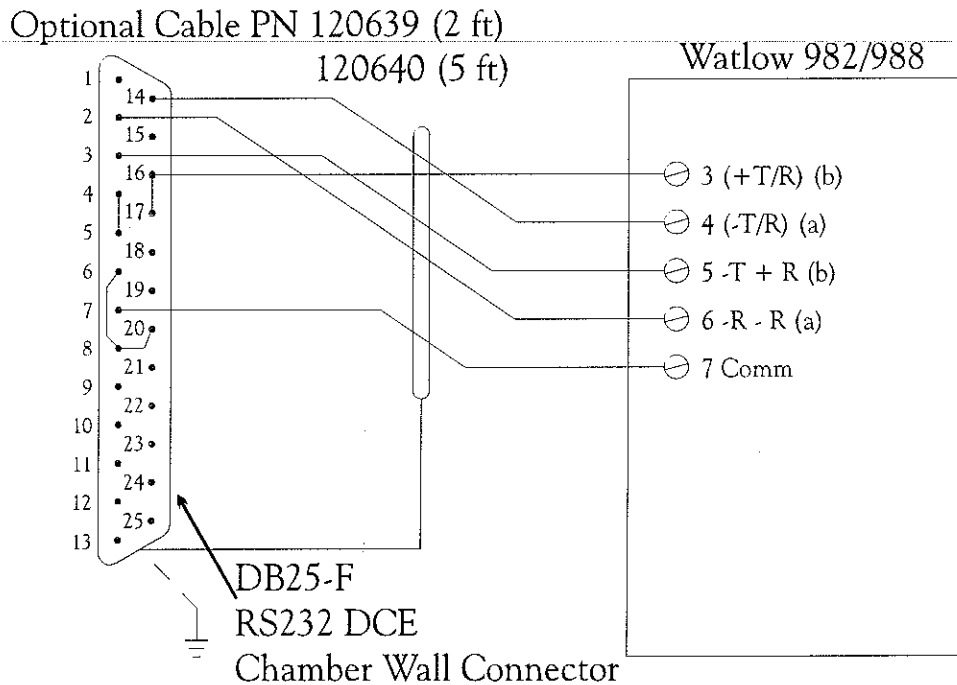

Figure 11. Optional W982/986 Communications Cable Connection
RS422

Serial Data Transmission

Serial data transmission is the most common method of sending data from one DTE to another. Data is sent out in a stream, one bit at a time, over one channel.

When a computer is instructed to send data to another DTE, the data within the computer must pass through a serial interface to exit as serial data. Then it passes through the ports, cables and connectors that link the various devices. The boundaries (physical, functional and electrical) shared by these devices are called interfaces.

RS-232C defines three types of connection: electrical, functional and mechanical. The most commonly used interface, it is ideal for the data transmission range of 0-20 Kbps, 50 ft. (15.2m). It employs unbalanced signaling and is usually used with 25-pin D-shaped connectors (DB25) to interconnect DTEs (computers, controllers, etc.) and DCEs (modems, converters, etc.). Serial data exists through an RS-232C port via the Transmit Data (TD) lead and arrives at the destination device's RS-232C port through its Receive Data (RD) lead. (RS-232C is compatible with these standards: CCITT V.24, V.28; ISO IS2110.)

RS-530 supersedes RS-449 and complements RS-232. Based on a 25-pin connection, it works in conjunction with other electrical interface RS-422 (balanced electrical circuits) or RS-423 (unbalanced electrical circuits). RS-530 defines the mechanical electrical interfaces between DTEs and DCEs that transmit serial history data, whether synchronous or asynchronous. RS-530 provides a means for taking advantage of higher data rates with the same mechanical connector used for RS-232. However, RS-530 and RS-232 are not compatible!

RS-530 accommodates data transmission rates from 20 Kbps to 2 Mbps; maximum distance depends on which electrical interface is used. (RS-530 is compatible with these standards: CCITT V.10, V.11, X26; MIL-188 114; RS-449.)

RS-232 Interface (Male) DTE (Computer, Terminal)

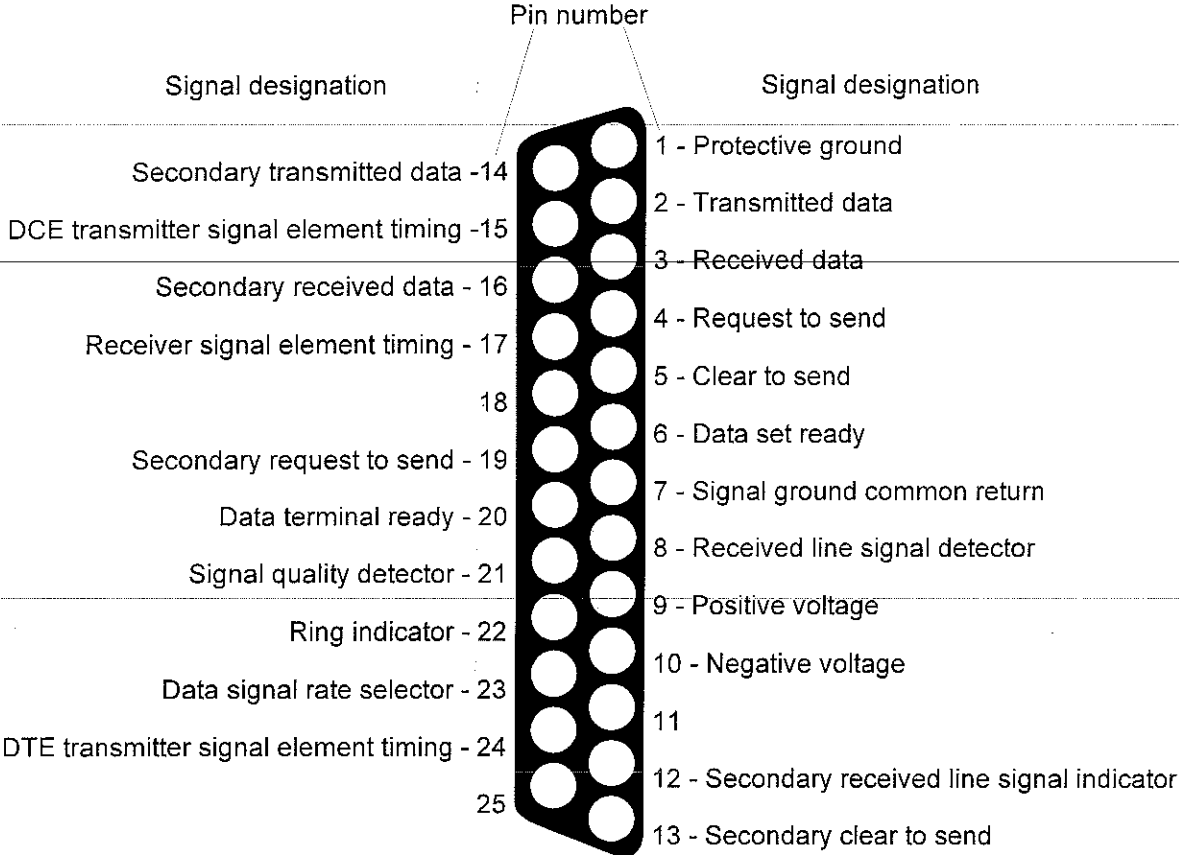

RS-530 Interface (Male) DTE (Computer, Terminal)

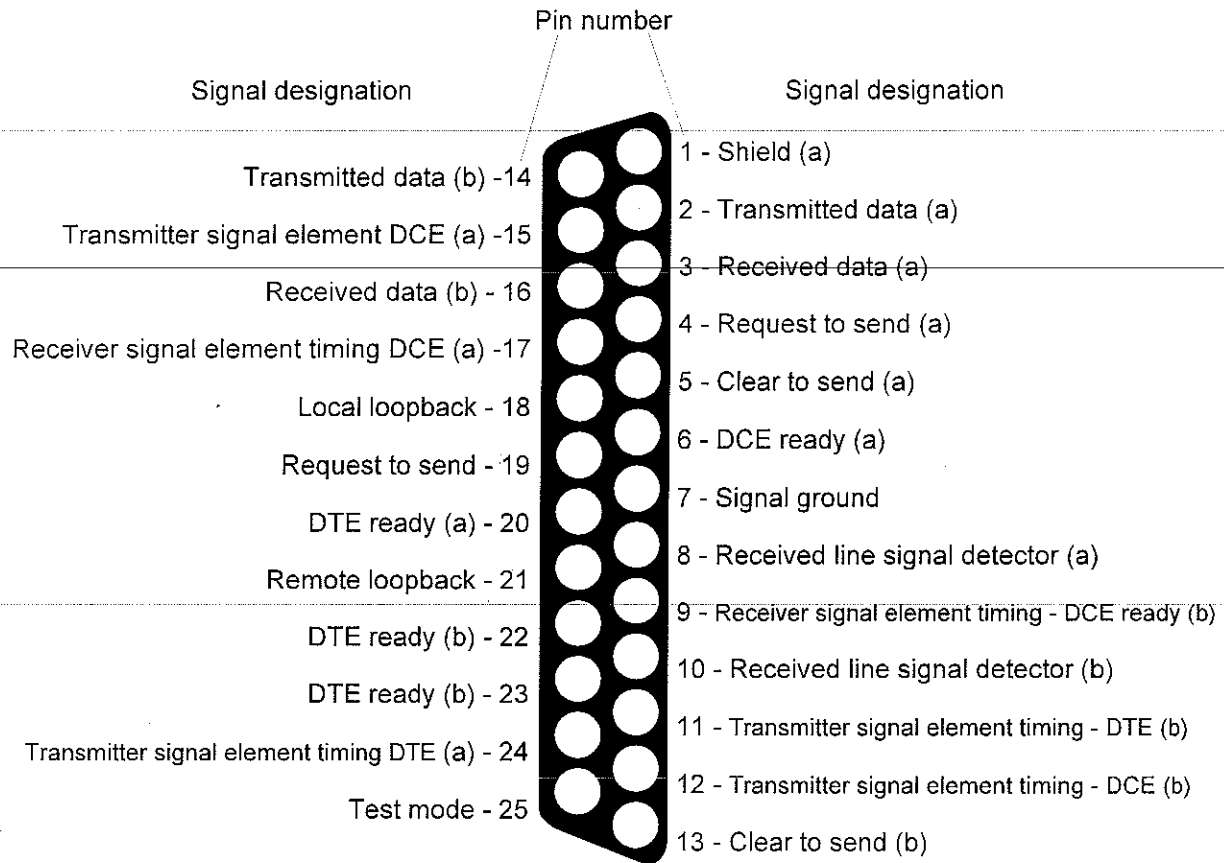

Accessory Cabling and Connectors

Part No.	Name	Function
124280	DB25M	Connects to chamber (DCE)
124282	DB09F	Connects to AT or later comm. port
124281	DB25	Connects to RS-232 DTE (old 25-pin comm. port)
124284	Cable	UTP Category 4, 3 pair pin-to-pin wiring, 7' lg.
124283	RJ-11	Tee connector for hooking up RS-485 and RS-422 in daisy chain piggy back fashion

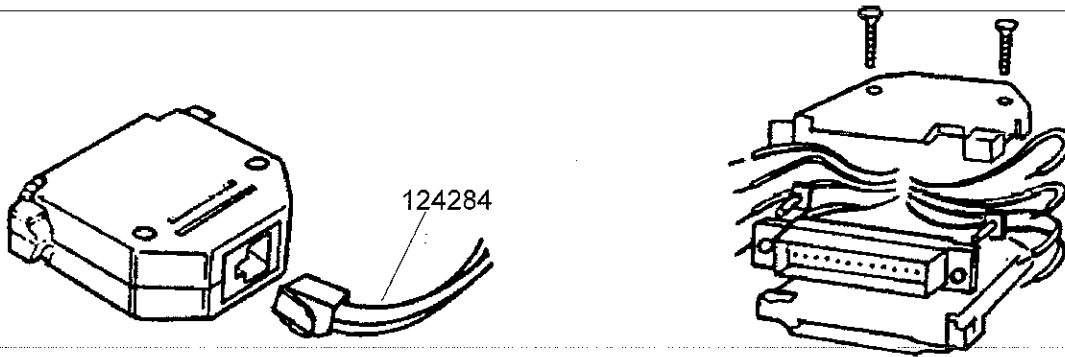

Figure 12. FDB Connector to the RJ-11 Rack

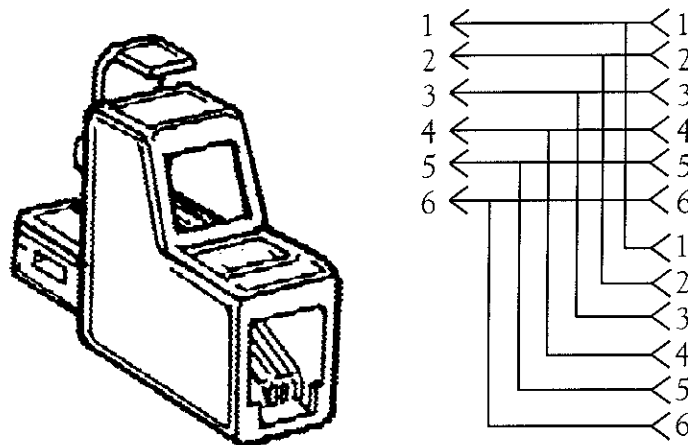

Figure 13. F-type 267 Piggyback Configuration T Adapters and a 267e Schematic

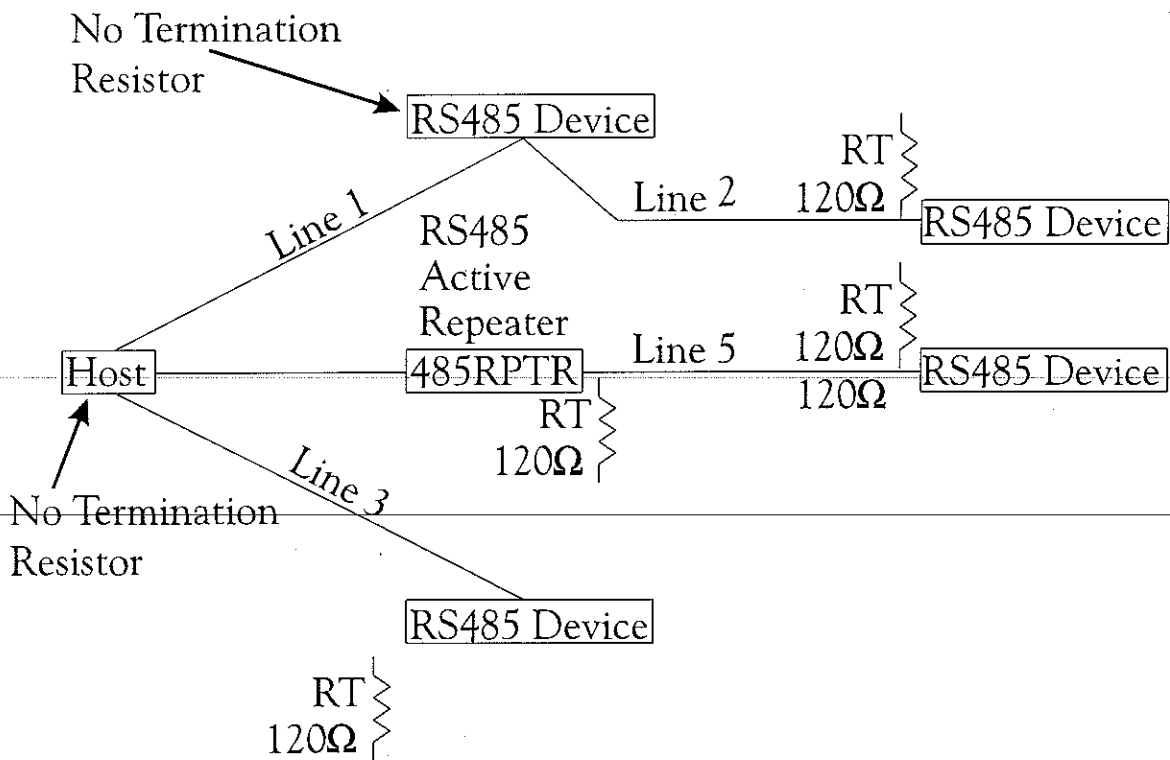

Figure 14. Star Network Using RS-485 Repeater

Optional cables and connectors can connect a network of devices to the host computer. Devices in the middle of the line (e.g. Line 1) would use the RJ-11 tee connector. The last device in a line should have a 90 to 120 resistor across the twisted pair.

Lines 1, 2 and 3 must not total more than 4,000 feet. Line 5 can be up to 4,000 feet.

MAINTENANCE

DO NOT service this equipment without first disconnecting the electrical power to this unit. Disconnect main power switch or power cord. There are live circuits and connections even with power switch off.

Repair of electrical systems should be performed by qualified mechanics only. Refer to the enclosed wiring and piping schematics with bills of materials for description and function of components.

Keep equipment clean. Gradual dirt accumulation impedes air flow. A dirty chamber can result in unsatisfactory operation such as non-uniform temperatures and/or humidity in the work chamber, reduced heating capacity, reduced production, overheated components, reduced refrigeration capacity, etc.

Keep the walls, floor and ceiling of the work chamber free of corrosion, dirt, and dust. Floating dust or accumulated dirt may produce unsatisfactory test results.

Keep all equipment accessible. Do not permit other materials to be stored or piled against chamber.

Protect controls against excessive heat. This is particularly true of controls, motors or other equipment containing electronic components. Temperatures in excess of 38 °C (100 °F) should be avoided.

Establish maintenance and check-up schedules. Recommended frequency for scheduled maintenance is included in each section.

Follow these promptly and follow them faithfully. Careful operation and maintenance will be more than paid for in continuous, safe and economical operation.

Maintain equipment in good repair. Make repairs immediately. Delays may be costly in added expense for labor and materials and prolong eventual shutdown.

Lubrication. Fan motor bearings are permanently lubricated. All door latches, hinges, door operating mechanisms, bearing or wear surfaces should be lubricated to ensure easy operation.

Check safety controls. This should be done as indicated. Make these tests carefully and do them regularly. The safety of personnel as well as the equipment may depend upon the proper operation of any one of these controls at any time.

- Temperature Controllers (weekly)

Observe that the heater or cooling indicator lights (LEDs L1 or L2) flash every 1 to 2 seconds when the controls are operating at set point.

- High Limit Control (weekly)

With the oven operating at a given temperature, gradually turn the HI-LIMIT control down to the set point operating temperature. The HI-LIMIT should trip and shut off heater fan.

Practice safety. Make it a prime policy to know what you are doing before you do it. Make CAREFULNESS, PATIENCE and GOOD JUDGMENT the safety watchwords for the operation of your chamber.

Ventilation. There are fresh air and exhaust openings on the chamber that are always open to provide cooling for the chamber and control compartment.

Door gaskets and ports. Periodically inspect inner and outer door gaskets and port sealing for cracking, tearing, etc. If gaskets or seals are damaged, remove and replace. Strip old gasket from channel and force new gasket in.

Preventative Maintenance Schedule. The following pages contain a typical periodic maintenance schedule for the 900 Series test chamber.

Preventative Maintenance Schedule

Insure trouble-free service by performing preventive maintenance when appropriate. Should service be required, specific procedures are described to locate and repair malfunctions.

Item Description	Reading	Months of Operation				
		1	3	6	9	12
1. Inspect door seals checking for proper seating, damage or tears. Adjust and/or replace as necessary.				X		
2. Inspect the door operation. Should open and close easily.				X		
3. Inspect recirculation fan. Make sure it is clean and free of dust build-up.				X		
4. Measure and record the line voltage. If the voltage is not $\pm 10\%$ of the nameplate specification, discontinue use and take corrective action.				X		
6. Measure and record the recirculation fan motor current draw.				X		
7. Measure and record the amp draw of the air heater. Verify the actual amps with the amp draw listed on the electrical schematic.				X		
8. Make a visual inspection of the control panel area. Make sure the electrical components are clean and free of dirt or dust buildup. CAUTION: CLEAN ONLY AFTER TURNING OFF THE POWER AT THE POWER SOURCE.				X		
9. Inspect the equipment instrumentation. Check the controller, limit controller(s), and recorder calibration using a certified calibration standard. Update the calibration standards. Complete a certificate if required.				X		
10. Check for proper operation of the High and Low limit controllers. Adjust the limits to assure they will "trip" in an overtemperature condition.				X		
11. Overall functional test. Operate the equipment and check the functionality of the heating, cooling (if equipped) systems. Adjust controller tuning if necessary.				X		
12. Record all parameters in the control instrument. Keep a copy on sight and send a copy to Despatch.				X		

Test Equipment Required

The following equipment is needed to perform maintenance and calibration operations on temperature test chambers.

- Temperature calibrator (minimum adjustment 0.1 °C or less).
- Multitester, 100k ohms/volt, or VOM.

Chamber

The temperature test chamber should be inspected for conditions that might damage it or shorten its service life and should be cleaned at frequent intervals.

Temperature test chamber inspection consists of the following checks.

- Inspect the coolant cylinder valves to be sure they are properly closed.
- Inspect the inside of the test chamber for moisture. If moisture is found, operate the test chamber for one hour at 205 °C (400 °F) to evaporate the moisture.
- Check coolant lines for proper connections.
- Check the test chamber motor(s) at elevated temperatures for quiet operation. (This insures proper bearing condition.)

WARNING:

Always disconnect the AC power to the test chamber before performing preventive maintenance.

Maintenance should be performed by qualified personnel only.

Coolant Solenoid Orifice Assembly

The coolant solenoid orifice assembly should be cleaned only when necessary. Frequent cleaning should not be required if contaminant-free CO₂ is always used. Clean the coolant orifice as follows.

1. Disconnect AC power.
2. Disconnect coolant hose.
3. Remove vent screen from control unit compartment.
4. Open heater compartment.
5. Remove coolant solenoid assembly from control unit compartment.
6. Remove orifice tube from solenoid assembly.
7. Check position of orifice for reinstallation.
8. Carefully clean orifice using 0.46 mm (0.18 inch) diameter music wire.
9. Replace orifice tube in solenoid assembly, performing the removal procedure in reverse order.
10. Reinstall coolant solenoid assembly in control unit compartment.
11. Close control unit and heater compartment.
12. Connect coolant hose.
13. Turn on coolant cylinder valve and check for leaks.
14. Connect AC power.
15. Operate test chamber at low temperature set-point to insure correct cooling function.

CO₂ Filter

The CO₂ filter should be cleaned every 30 days or 240 hours of operation, whichever occurs first. See Figure 2 in this manual. Clean the CO₂ filter as follows.

1. To remove the filter, unscrew the hollow Allen head screw from the test chamber bulkhead fitting and slide the filter out from the fitting.
2. Wash filter in trichloroethylene.
3. Dry filter thoroughly with filtered, dry, compressed air at low pressure.
4. Reinstall filter in CO₂ bulkhead fitting.

WARNING:
Use trichloroethylene only in a well ventilated area. Avoid inhaling fumes and excessive contact with the skin.

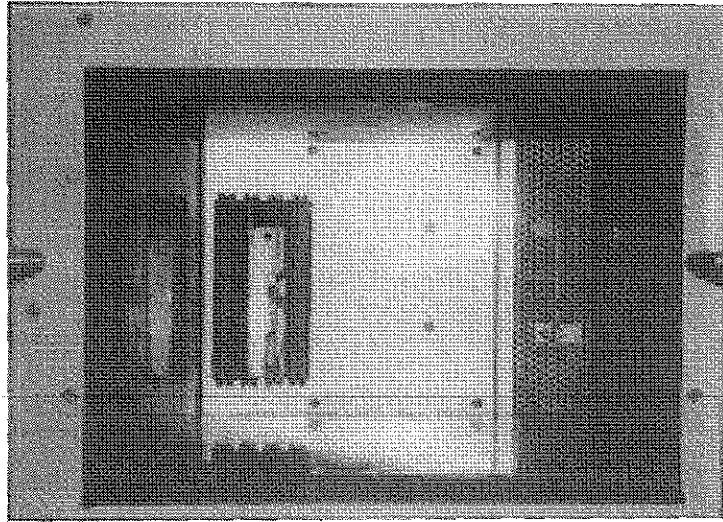

Figure 15. Plenum Plate Before Removal

Corrective Maintenance

The purpose of corrective maintenance is to locate test chamber malfunctions and to apply proper repair procedures. The following procedure is used in troubleshooting the test chamber.

1. Insure that all switches are in the proper position.
2. Check first for blown fuses and proper AC power connection.
3. Check coolant lines for proper plumbing. Check that all line valves are open. Make sure that the coolant lines are not clogged.
4. Check the coolant cylinders to be sure that they contain an adequate coolant gas supply.

Components in the temperature test chamber are removed and replaced as follows:
Repair is limited to the replacement of defective parts.

1. Disconnect AC power.
2. Remove screws holding plenum plate.
3. Carefully allow plenum plate away from the heater assembly.

CAUTION:
Care should be taken not to damage or disturb the location of the thermocouples.

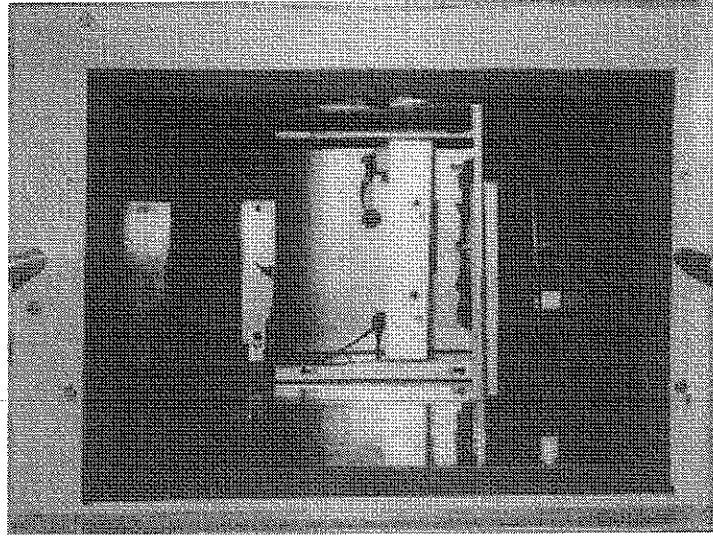

Figure 16. Plenum Plate After Removal

4. Remove two Phillips-head screws at the back of the heater assembly.
5. Remove the two wires connected to the heater coil.
6. Carefully remove heater from chamber.
7. To replace heater assembly, perform the removal procedure in reverse order.

Service Procedures

Main Blower Motor

Remove the main blower motor as follows.

1. Disconnect AC power.
2. Remove screws holding plenum plate.
3. Carefully allow plenum plate to drop downward.
4. Loosen Allen set screw holding blower motor fan blade or blower wheel to motor shaft.
5. Remove fan blade or blower wheel. In some cases, a gear puller will be needed for removal of the fan from the motor shaft.
6. Remove vent screws from control unit compartment.
7. Remove blower motor wires from terminal strip.
8. Remove three Phillips-head screws connecting the blower motor to this mounting platform.
9. On models 934 and 936, remove motor shaft pin.
10. Remove blower motor.
11. To replace blower motor, perform the removal procedure in reverse order.

CAUTION:

Do not damage thermocouples or disturb placement.

Electronic Control Chassis

Remove the electronic control chassis as follows.

1. Disconnect AC power.
2. Remove vent screen from motor compartment.
3. Remove holding screw located above rear of Watlow 982 control within motor compartment. (On Models 934, 924, 936, and 926.)
4. Remove two holding screws on rear of chamber near the serial interface connector.
5. Remove holding screws (two on Models 934, 924, 936 and 926 on exterior bottom of chamber; three holding screws through chassis on Models 925 and 936).
6. Remove wires connected to terminal strip, or remove screws fastening terminal block to bulkhead.
7. Remove control chassis by sliding it towards the front of the chamber.
8. To replace the control chassis, perform the removal procedure in reverse order.

HI-LIMIT Thermoswitch

Adjust and test the factory calibrated HI-LIMIT thermoswitch as follows.

1. The thermoswitch was factory set and tested at the chamber maximum rated temperature within normal tolerance.
2. If necessary to reset the thermoswitch. It is accessible by removing the snap in closure button in the rear cover panel.
3. A screwdriver can be inserted through the hole to find the end of the slotted adjusting screw.
4. Turn screw clockwise to reduce temperature. Adjusting rate is approximately 90 °F per revolution.
5. To set a new temperature on the thermoswitch.
 - a. Set the chamber control to the desired trip temperature and allow temperature to stabilize.
 - b. The panel mounted overtemperature setpoint must be set at a higher temperature for this test.
 - c. Slowly turn adjusting screw clockwise until the thermoswitch trips and the chamber is shut down.
6. Test the setpoint.
 - a. Allow the chamber to cool.
 - b. Open and close the power switch to reset.
 - c. Set the chamber controller above the set point.
 - d. Observe the temperature at the time it is tripped.

The chamber with thermoswitch UE8625 will be reset automatically when the temperature drops below the over- temperature set point.

7. Reset the electronic overtemperature set point to the desired temperature.

APPENDIX

IEEE 488 Interface Converter Set-up

Three DIP switches internal to the interface converter set the configuration of the interface.

Selectable functions are read **ONLY** at power-on and should only be set prior to applying power to the interface. The following lists the Despatch factory recommended conditions.

Serial Port	IEEE
9600 Baud	Mode = IEEE488 Peripheral
7 Data Bits	Address = 10
1 Stop Bits	Bus Terminator = LF; EOI Disabled
Odd Parity	Talk-back on Terminator Enabled (SRQ)
Serial Terminator = CR	Talk-back on Time Out Enabled
Echo Disabled	
XON/XOFF Handshake	

(Watlow device must be configured same as above.)

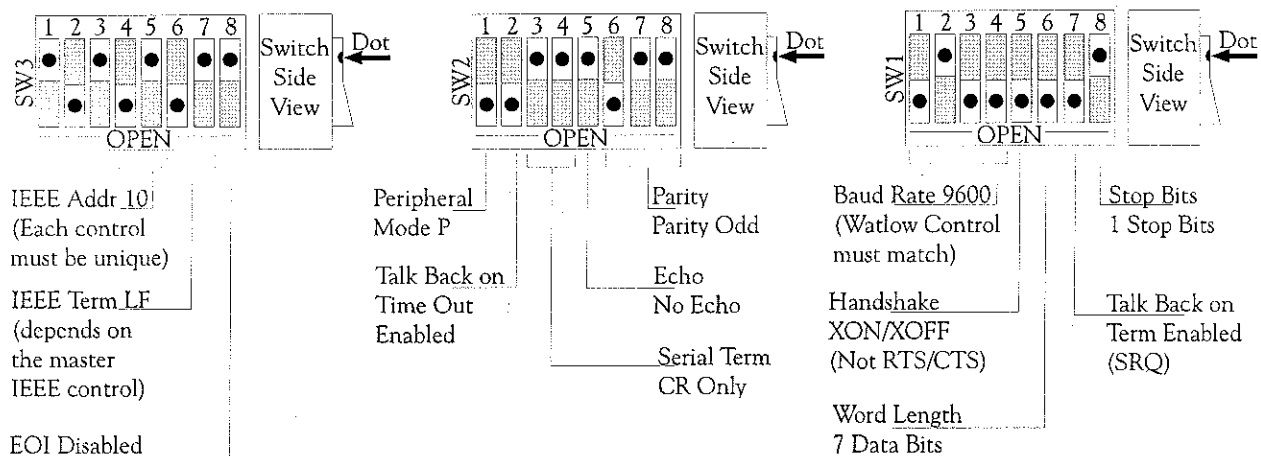

Figure 17. Factory Default Settings

Note that the interface converter may be configured as an IEEE controller. In this mode the interface converter is designed to allow an RS-232 computer to communicate with an IEEE peripheral such as a plotter. This controller mode is described in detail in Section 3 of the Black Box instruction manual. Note that in this mode the address selected is that of the IEEE488 device that the converter is addressing.

The interface converter may also be configured as an IEEE peripheral. As an IEEE peripheral, the interface converter allows an IEEE controller to communicate with an RS-232 device (e.g., Watlow control). The peripheral mode of operation is described in detail in Section 4 of the Black Box manual. Note in this mode the address selected is for the IEEE488 converter itself. Each Watlow device must have its own converter with a unique address.

To modify any of these defaults, follow this simple procedure: Disconnect the power supply from the AC line and from the interface. Disconnect any IEEE or serial cables prior to disassembly.

WARNING:
 Never open the interface converter case while it is connected to the AC line. Failure to observe this warning may result in equipment failure, personal injury or death.

Place the interface upside down on a flat surface. Remove the four (4) screws located near the rubber feet. Return the interface to the upright position and carefully remove the top cover. Modify those parameters which are appropriate for your installation and then carefully reassemble the interface using the reverse of the procedure described.

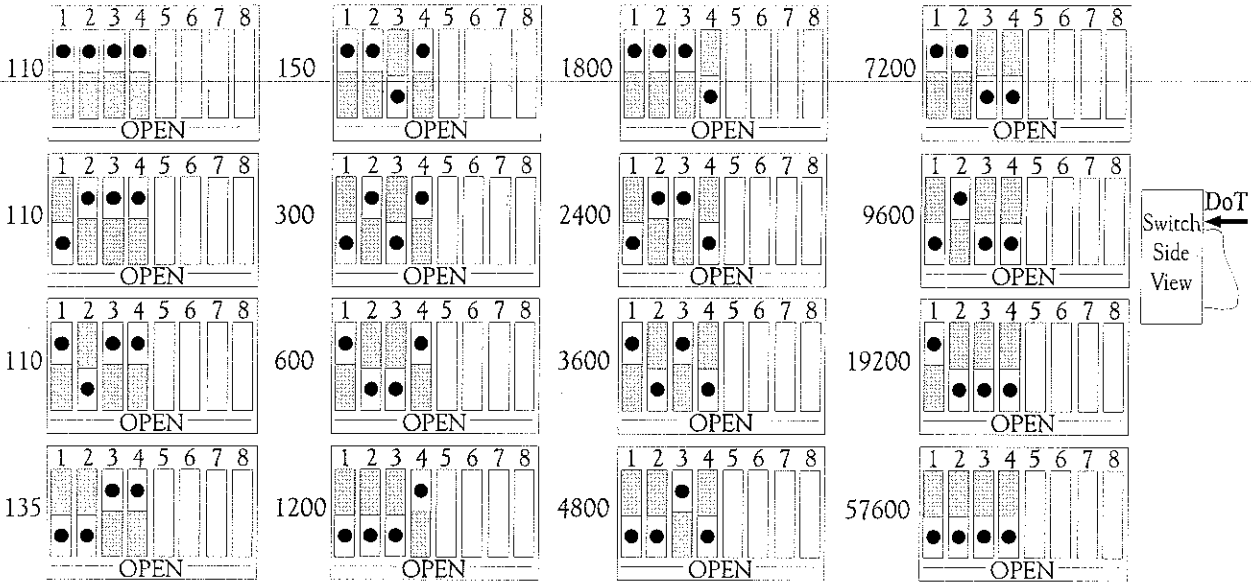

Figure 18. SW1 View for Serial Baud Rate Selection

IEEE 488 Interface Converter

The interface converter has the ability to output signal levels that are compatible with either RS-232 or RS-422. An internal DIP shorting plug determines which electrical specification is chosen. If the interface is to be connected to an IBM PC/XT/AT/PS2 or compatible, the RS-232 level should be selected. If it will be connected to a Macintosh 512K/Plus/SE/II, the RS-422 level should be used. For connection to other computers, refer to the manufacturer's manual to determine which levels are supported. Most Watlow controls are available both in RS-232 and RS-422 hardware. Make sure to match your Watlow device. RS-232 is most common.

RS-232/RS-422 Signal Level Selection

The interface converter's factory default signal levels are compatible with RS-232. To select RS-422 levels, carefully remove the 8-position shorting plug with a small flat blade screwdriver from J106. Install the DIP jumper into J205, making certain that all of the pins on the shorting plug are inserted correctly. The RS-232 position generally works best with the Watlow controls.

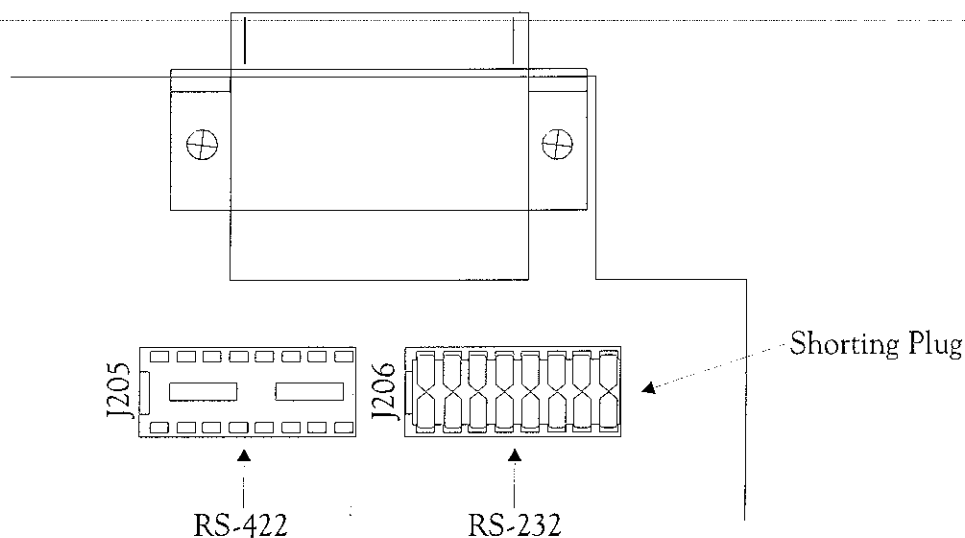

Figure 19. Selection of RS-232 or RS-422 Signal Levels

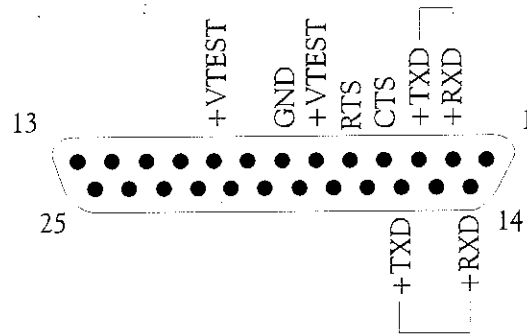

Figure 20. Rear View of Interface Converter's Serial Connector

Serial Signal Descriptions

The interface converter is equipped with a standard DB-25S connector on its rear panel and requires a standard DB-25P mating connector. The interface converter's connector is configured as DCE type equipment for RS-232 communications, which means the interface converter always transmits data on Pin 3 and receives data on Pin 2. The following lists and describes the RS-232 and RS-422 signals provided on the interface converter. The RS-422 pin outs are made similar to RS-530 DCE.

Pinout Descriptions

Pin Out		Description
-RxD	Receive Data Input - Pin 2	This pin accepts serial data sent by the RS-232 or RS-422 host. The serial data is expected with the word length, baud rate, stop bits and parity selected by the internal switches. The signal level is low true.
-TxD	Transmit Data Output - Pin 3	This pin transmits serial data to the RS-232 or RS-422 host. The serial data is sent with the word length, baud rate, stop bits and parity selected by the internal switches. The signal level is low true.
CTS	Clear to Send Input - Pin 4	The CTS input is used as a hardware handshake line to prevent the interface converter from transmitting serial data when the RS-232 host is not ready to accept it. When RTS/CTS handshake is selected on the internal switches, the interface converter will not transmit data out -TxD while this line is unasserted (low). If the RS-232 host is not capable of driving this line it can be connected to the Vtest output (Pin 6) of the interface converter. If XON/XOFF handshake is selected, the CTS line is not tested to determine if it can transmit data.
RTS	Request to Send Output - Pin 5	The RTS output is used as a hardware handshake line to prevent the RS-232/RS-422 host from transmitting serial data if the interface converter is not ready to accept it. When RTS/CTS handshake is selected on the internal switches, the interface converter will drive the RTS output high when there are greater than 1,000 character locations available in its internal buffer. If the number of available locations drops to less than 1,000, the interface converter will unassert (low) this output. If XON/XOFF handshake is selected, the RTS line will be permanently driven active (high).
Vtest	Test Voltage Output -Pin 6	This pin is connected to +5 volts through a 1K resistor. It is also common to Vtest on Pin 9.
Gnd	Ground Pin 7	This pin sets the ground reference point for the other RS-232 inputs and outputs.
Vtest	Test Voltage Output - Pin 9	This pin is connected to 5 volts through a 1K resistor. It is also common to Vtest on Pin 6.
+RxD	Receive Data Plus Input - Pin 14	This pin accepts serial data sent by the RS-422 host. The serial data is expected with the word length, baud rate, stop bits and parity selected by the internal switches. The signal level is high true and only connected to this pin when RS-422 operation is selected. It is 180 degrees out of phase with -RxD .
+TxD	Transmit Data Plus Output - Pin 16	This pin transmits serial data to the RS-422 host. The serial data is sent with the word length, baud rate, stop bits and parity selected by the internal switches. The signal level is high true and only connected to this pin when RS-422 operation is selected. It is 180 degrees out of phase with -TxD .

XON/XOFF Protocol

Your Watlow control is selectable for use with one of two protocols:

- XON/XOFF, used when one master controls one Watlow.
- ANSI X3.28-1976 Sub 2.2 and A3, used to address multiple units in a single serial (RS-422/485) line.

The XON/XOFF protocol on the Watlow uses a <CR> as a message terminator. The ANSI X3.28... uses various control characters (e.g., ETX, EOT).

The black box converter is a "smart" converter, which automatically takes care of much of the IEEE488 parallel side protocol. However, it requires either a carriage return or line feed text terminator on the serial side (RS-232, 422) in order for the converter to know when to time certain functions. For this reason, the Watlow control must be configured for XON/XOFF protocol.

This also means that each Watlow device is going to need its own converter, and each converter will need a unique IEEE address.

XON/XOFF Versus RTS/CTS Handshaking

Watlow interface ports do not support RTS/CTS handshaking so the black box converter must be configured for XON/XOFF also. (See dip switch settings.) Also, there must be a jumper between RTS and CTS pins in the black box DB25 serial connector. If you use Despatch-supplied cabling, the jumper is supplied within the cabling.

Sample Program

For the Black Box 488 to 232 converter.

```
10      ! Program for H-P 85 with HpiB Interface
        and Black Box 488 to 232 Converter to
        Talk
20      ! To a Watlow 982 Control, Copyright
        Despatch March 28, 1995
30      Clear 7
40      on Timeout 7 Gosub 340
50      Set Timeout 7; 3200
60      on Key# 1 Goto 220
70      on Key# 2 Goto 160
80      on Key# 3 Goto 410
90      on Key# 4 Goto 270

100     Clear
110     Disp "K1 to Read Setpoint"
120     Disp "K2 to Set Setpoint"
130     Disp "K3 to End"
140     Disp "K4 to Analyze R$"
150     Goto 150
160     ! Set Control Setpoint
170     Disp "Enter New Set Point"
180     Input P
190     Output 710 ; "=" sp1 "&val$(P)&chr$(13)
200     Print "Setpoint Changed to "; P
210     Goto 100
220     ! Read Control Setpoint
230     Output 710 ; "? sp1 "&chr$(13)
240     Enter 710 ; R$
250     Print "? Response = "; R$
260     Goto 150
270     ! String Analysis for R$
280     L=len(r$)
290     Print "# of Char in R$ = "; L
300     for I=1 to L
310     Print "Char # "; I; " of String Has Value = "; Num(r$(I))
320     next I
330     Goto 100
340     ! Print Status of Interface
350     Print "Interface Timeout"
360     for I=0 to 6
370     Status 7, I; S(i)
380     Print "Status Byte #"; I; " = "; S(i)
390     next I
400     Return
410     Disp "End"
420     End
```

Notes:

- HPIB interface is #7.
- Black Box is set for Address 10.
- Watlow control is set up for XON/XOFF.
- (Prot = on) mode.

Sample Output

? Response = aΩ9.0
Setpoint Changed to 5.5
? Response = aΩaΩ5.5
Setpoint Changed to 125
? Response = aΩaΩ125.0
Setpoint Changed to 2.5
? Response =aΩaΩ2.5

Troubleshooting

TROUBLE	PROBABLE CAUSE
No controller display reading when power switch is on.	Loose wiring. Faulty transformer (240V or 208V units only). Faulty readout. Power cord not plugged into outlet. Outlet not powered. Defective line fuse (F1). Defective POWER switch (S1). Defective power cord.
Blowing line fuse when power switch is turned on.	Defective (grounded or shorted) heater (HTR-1). Defective motor(s) (shorted). Defective solenoid valve (shorted) (L1). Short in filter, transformer (if installed) or control. Shorted wiring, or loose connection touching chassis.
Chamber temperature differs from setpoint indication.	Defective sensor (1 or both). Control input parameters incorrect. Control out of calibration. Defective control.
Lack of operation of appropriate heat (L1) or cool (L2) LED when control setpoint differs from display by more than 0.3°C.	Defective controller. Control output and PID parameters incorrect.
Failure to control at a low temperature when cool (L2) LED is on.	Cylinder valve not open. Lack of liquid coolant. Clogged CO ₂ filter. Clogged orifice. Clogged line. Solenoid valve will not open. Defective solid state relay (SSR2).
Failure of chamber to heat when heat(L1) LED is on.	Faulty heater fuse (F2). High limit (Dial) set below chamber temperature. Defective solid state relay (SSR1). Defective contactors (K1 or K2). Defective heater (HTR-1). Defective heater cable. Solenoid valve will not close. Defective control.
Failure of solenoid valve to close when cool (L2) LED is off.	Ice in valve. Defective valve. Defective solid state relay (SSR2). Defective control.
Failure of solenoid valve to open when cool (L2) LED is on.	Defective valve. Defective solid state relay (SSR2). Defective control.

Bill of Materials

Quantity			Item	Part No.	Description
Model					
924/ 934	925/ 935	926/ 936			
1	1	1	W982	119097	Temperature Controller W982S-10CC-CUCD
1	1	1	A1-5	120639	Remote Digital Interface Cable
1	0	0	B1	62328	Fan Motor 0.02 HP KP-E29-BOL
0	2	0	B1 & B2	62327	Fan Motor 0.08 HP KP-G330-BOL
1	2	0	Cap	57348	Motor Capacitor 3MFD 370 VAC
0	0	1	B1	60619	Fan Motor 00.08 HP 5KCP19M5815
1	1	1	F1	007503	FNM/TRM 3.2A Fuse
1/0	1/0	1/0	F2	099906	FNM/TRM 20A Fuse
0/1	0/1	0/1	F2	094090	FNM/TRM 25A Fuse
0	1	0	HR1	60374	Air Heater Tuttle #1037 2KW
1	0	1	HR1	53007	Air Heater Tuttle #04-0739-01 2KW
1	1	1	K1	47753	Relay DPDT 25 Amp 120 Vac Coil
1	1	1	L1(L2)		Coolant Solenoid Valve
				134999	40PSI LN2 Predyne
				136689	300PSI LPCO2 Predyne
				136690	1000 PSI HPCO2 Predyne
1	1	1	S1	47116	Power Switch Carling Gray
1	1	1	S2	104609	High Limit Thermostat
1	1	1	S3	080177	Overtemp. Thermostat UE8625 or Vulcan 1D1B2
1	1	1	S4	075143	Switch Carling Ttb 1125 SPDT (Dual valve Ay's Only)
1	1	1	SSR1	47610	Solid State Relay Opto 22 240D25
1	1	1	SSR2	47611	Solid State Relay Opto 22 Z240D10
934	935	936			
1	1	1	1T	047617	Transformer Signal #241-6-1456
1	0	0	HR2	101970	Door Heater
0	1	0	HR2	102475	Door Heater
0	0	1	HR2	102494	Door Heater
1	0	1	HR3	101832	Shaft Heater
0	2	0	HR3	101671	Shaft Heater

Schematic Diagrams

Electrical schematics of the 924/934, 925/935 and 926/936 series are found on the following pages.

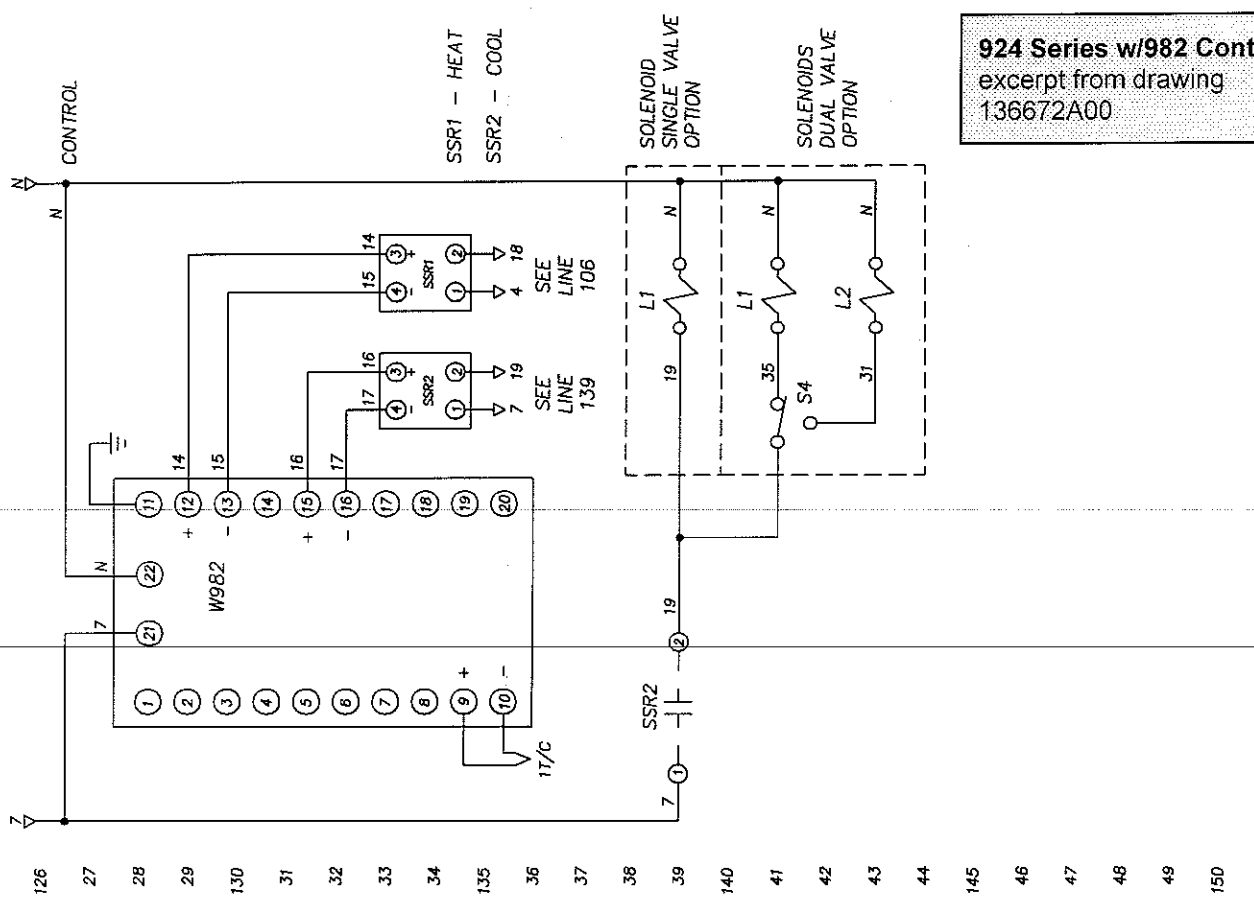

924 Series w/982 Control
 excerpt from drawing
 136672A00

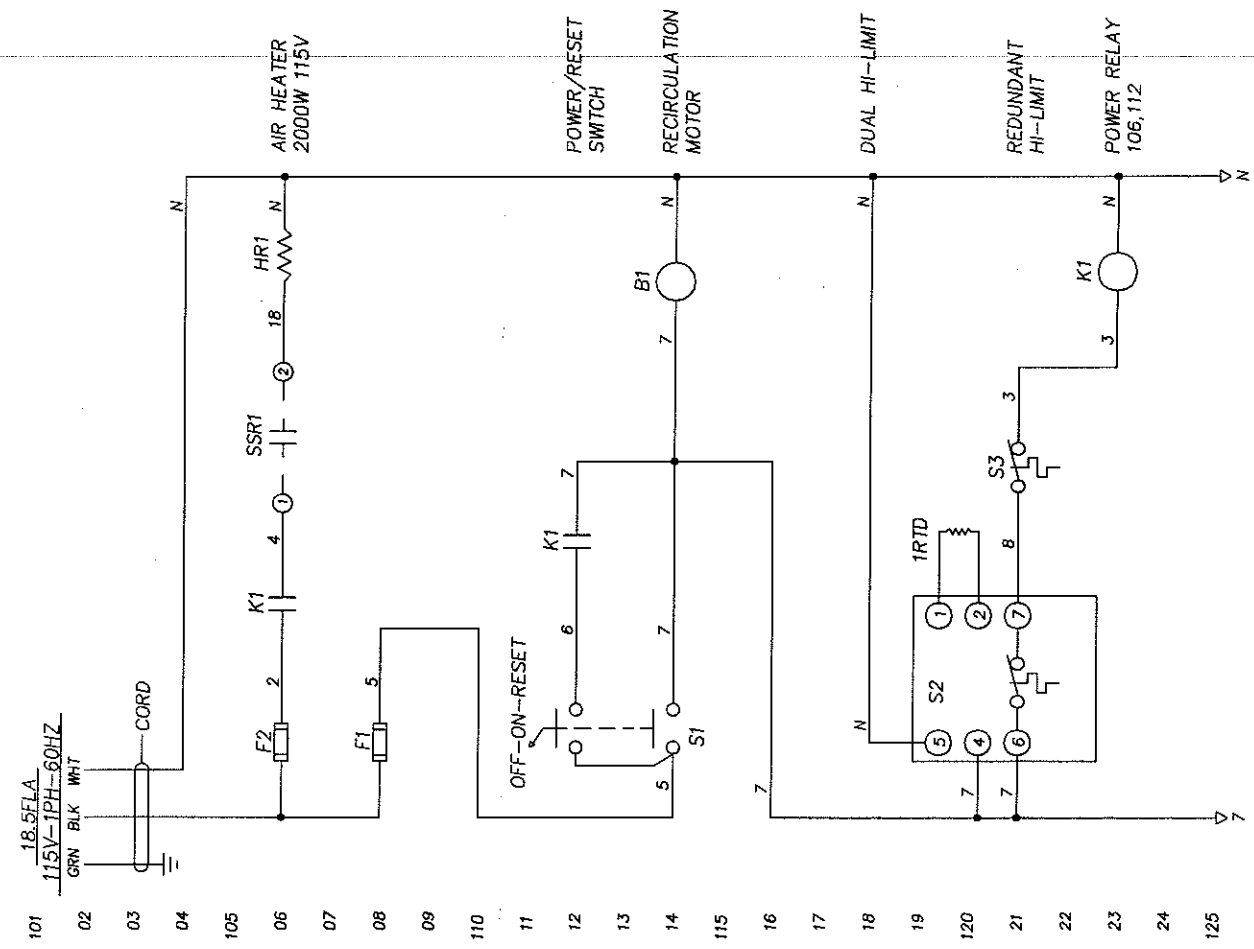

LIST OF MATERIAL		
ITEM	PART NUMBER	QTY DESCRIPTION
L1	136692	1 982S-1000-C002 RES23Z/48S
L2	052248	8T 17A 5 S1 BT W/P358 120V
L3	265987	1 FUSES/LOCK USM1 1P
F1	075503	1 FNU/7EM 3 2A FUSE
F2	265987	1 FUSES/LOCK USM1 1P
S1	094906	1 FNU/7EM 20.0A FUSE
S2	044587	1 SWITCH PAST OFF-ON-210M
R1	104608	1 RTD 1000 OHM FOR PAK STAT
S3	080757	1 THERMO CARTR 10192-A 24 OPEN ON RISE
K1	047513	1 RELAY 401EX 187-327020
SSR1	047511	1 RELAY SSR 2424A DC INPUT
SSR2	053007	1 HEATER 115V 2000W
H1	083238	1 MOTOR 1/2HP 115V
CAP	057248	1 CAPACITOR MOTOR 03 MFD 370V
L1	136692	1 M.V. SOL. IPR02 PREDIENE 350A 115V
L2	136699	1 M.V. SOL. IPR02 PREDIENE 350A 115V
L3	136690	1 M.V. SOL. IPR02 PREDIENE 1000# 115V
GND	132288	1 GROUND BUS (LOCATED ON CHASSIS)

DUAL VALVE OPTION		
ITEM	PART NUMBER	QTY DESCRIPTION
L2	136699	1 M.V. SOL. IPR02 PREDIENE 350A 115V
S4	075143	1 SW 718 112S SPDT

924 Series w/982 Control
 excerpt from drawing
 136672A01

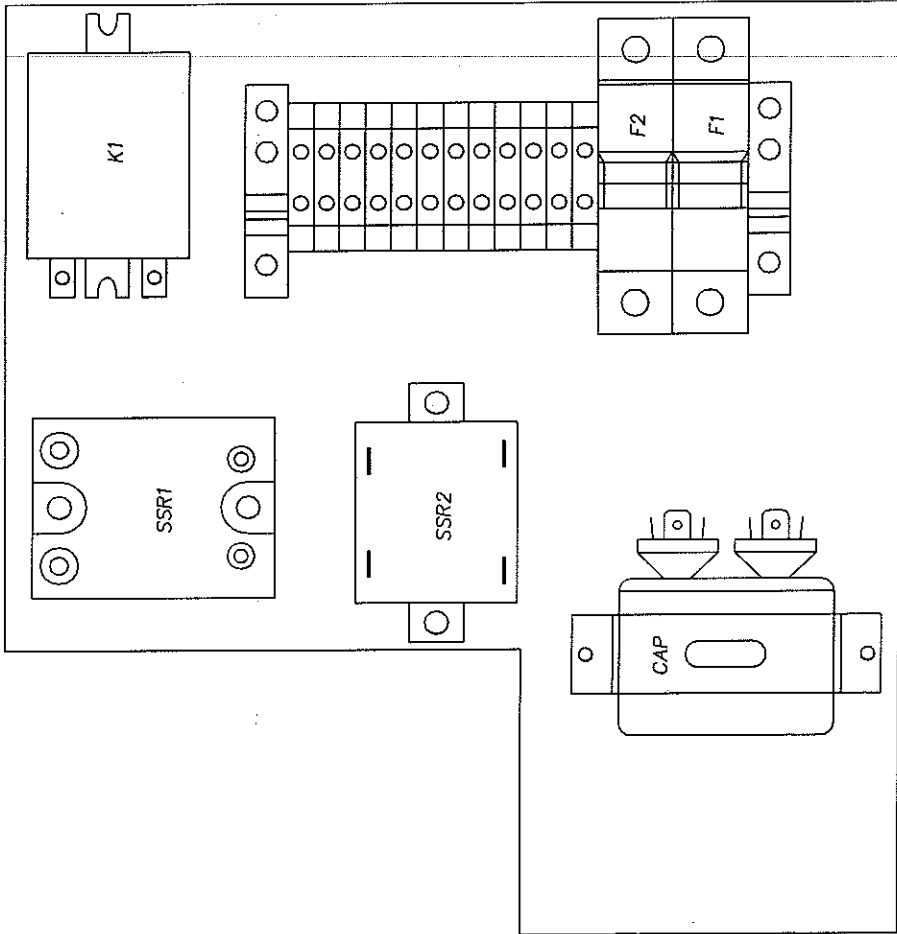
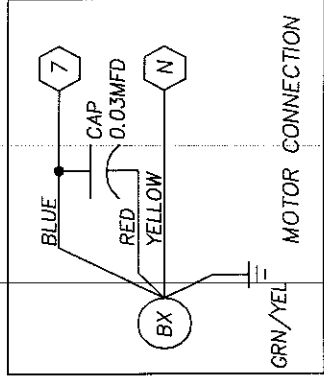
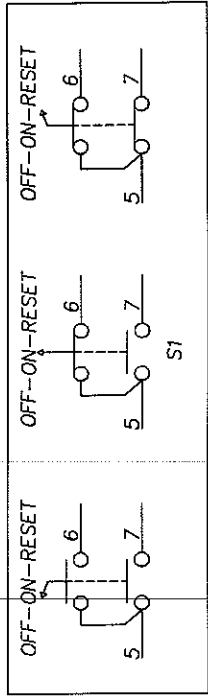

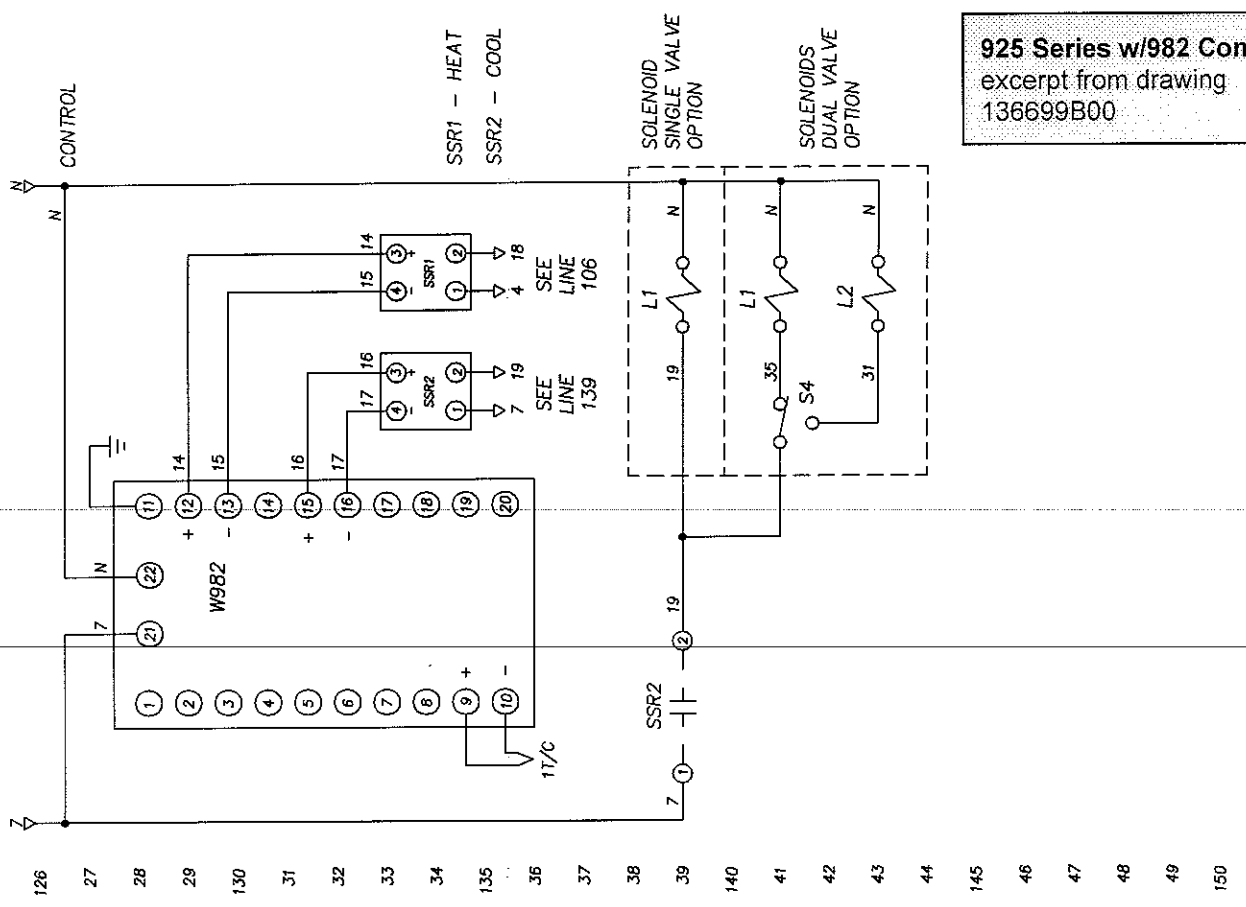

925 Series w/982 Control
 excerpt from drawing
 136699B00

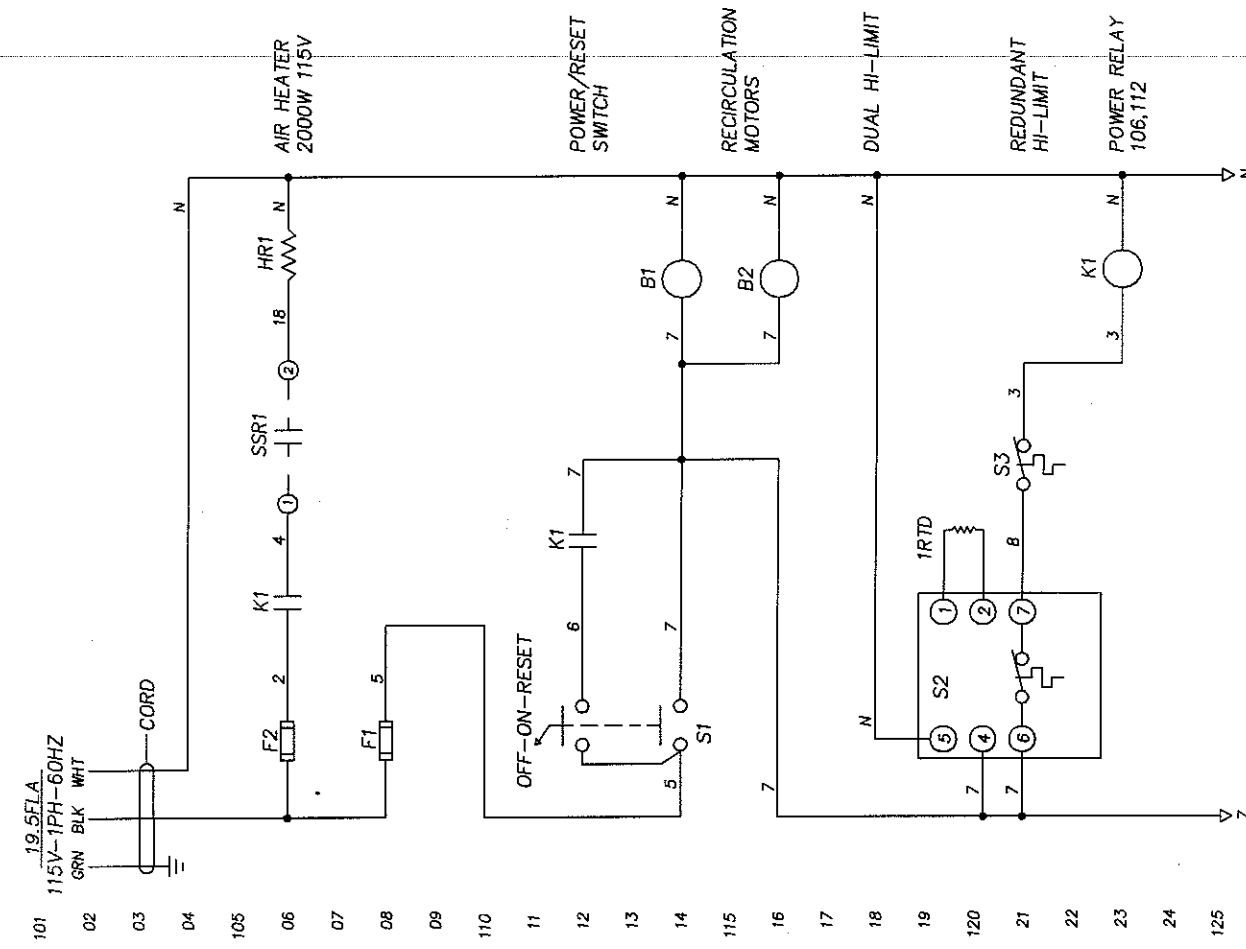

LIST OF MATERIAL

ITEM	PART NUMBER	QTY	DESCRIPTION
C1	119097	1	9925-10CC-CL00 83232/485
I1/C	052325	7FT	TYPE T T/C
CORD	074496	1	12-3 S/JT 9FT W/P-38 120V
F1	269987	1	FUSEBLOCK USMT 1P
F2	007503	1	FIM/TRM 3.2A FUSE
F3	205987	1	FUSEBLOCK USMT 1P
S1	099806	1	FIM/TRM 20.0A FUSE
S2	084657	1	SWITCH RESET GTE (ONL 240M
S3	104669	1	F44G018-30J PAK STAT
R1D	080705	1	RTD 1000 OHM FOR PAK STAT
S3	080777	1	THERMO CART 101B2-4-34 OPEN ON RISE
K1	047753	1	RELAY MIDTEX 1B7-321200
SSR1	047610	1	RELAY SSR 2240010 DC INPUT
SSR2	047611	1	RELAY SSR 2240010 DC INPUT
H1-2	060374	2	HEATER 115V 2000W
CAP	052348	2	MOTOR 08HP 115V
	134699	1	CAPACITOR MOTOR 0.03MFD 370V
L1	136689	1	VLV SOL LN2 PREDTNE 225# 115V
	136690	1	VLV SOL LPOC2 PREDTNE 350# 115V
GN1	132298	1	VLV SOL HPCO2 PREDTNE 1000# 115V
		1	GROUND BUS

DUAL VALVE OPTION

ITEM	PART NUMBER	QTY	DESCRIPTION
L2	136689	1	VLV SOL LPOC2 PREDTNE 350# 115V
S4	075143	1	SW ITB 1125 SPDT

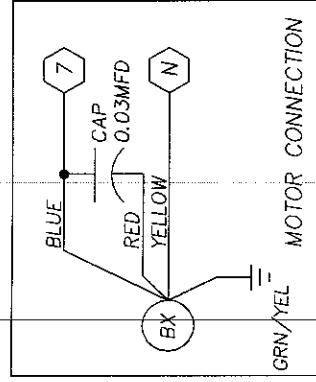
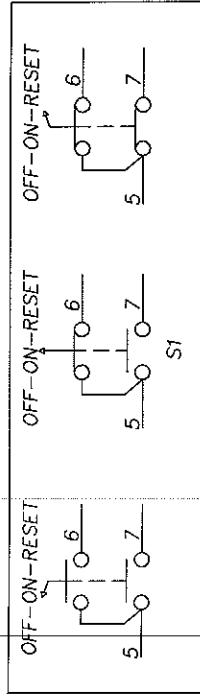

925 Series w/982 Control
 excerpt from drawing
 136699B01

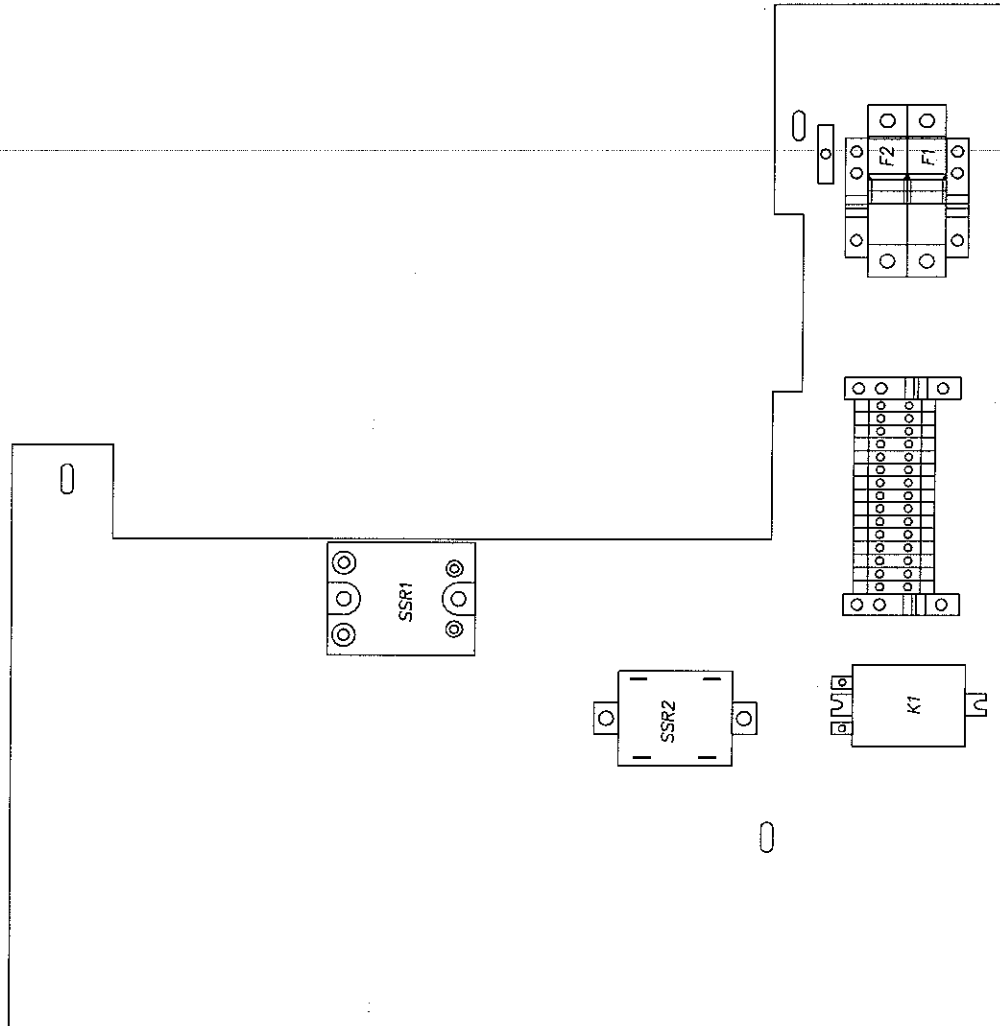

934 Series w/982 Control
 excerpt from drawing
 140316A00

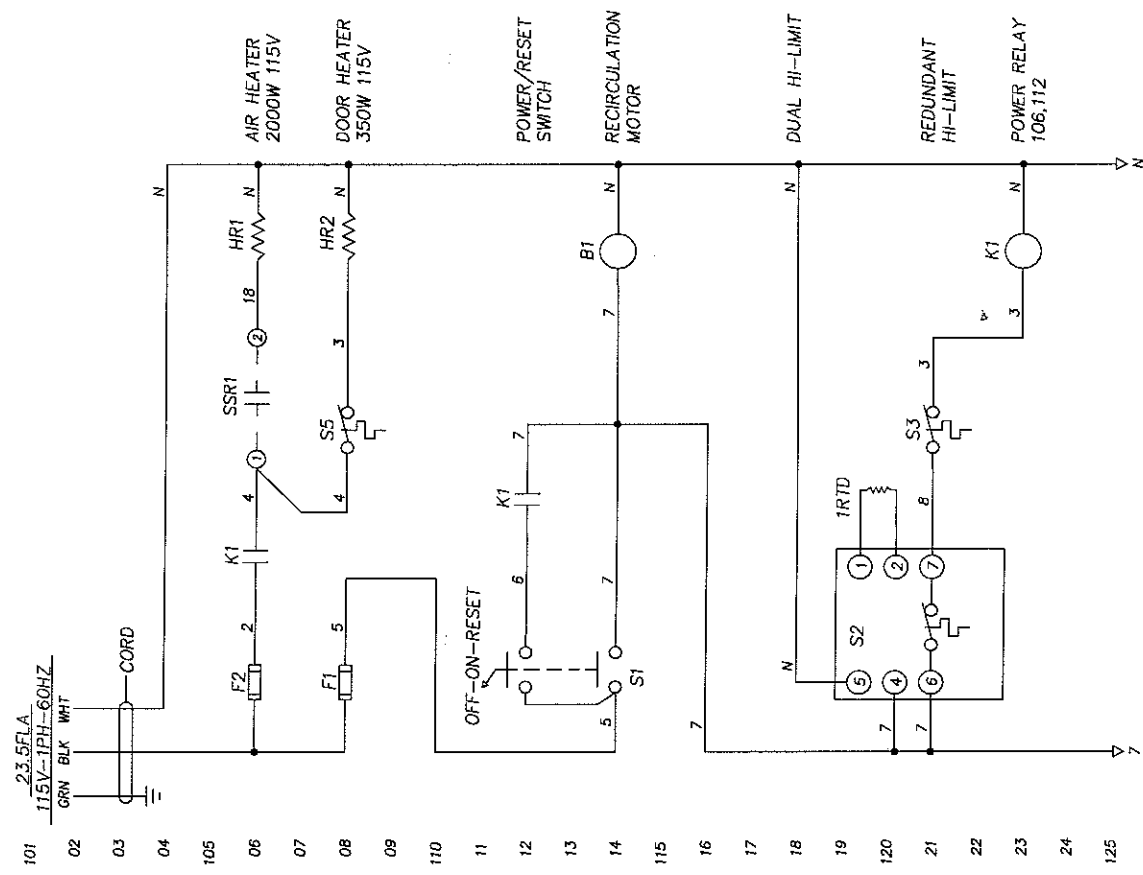
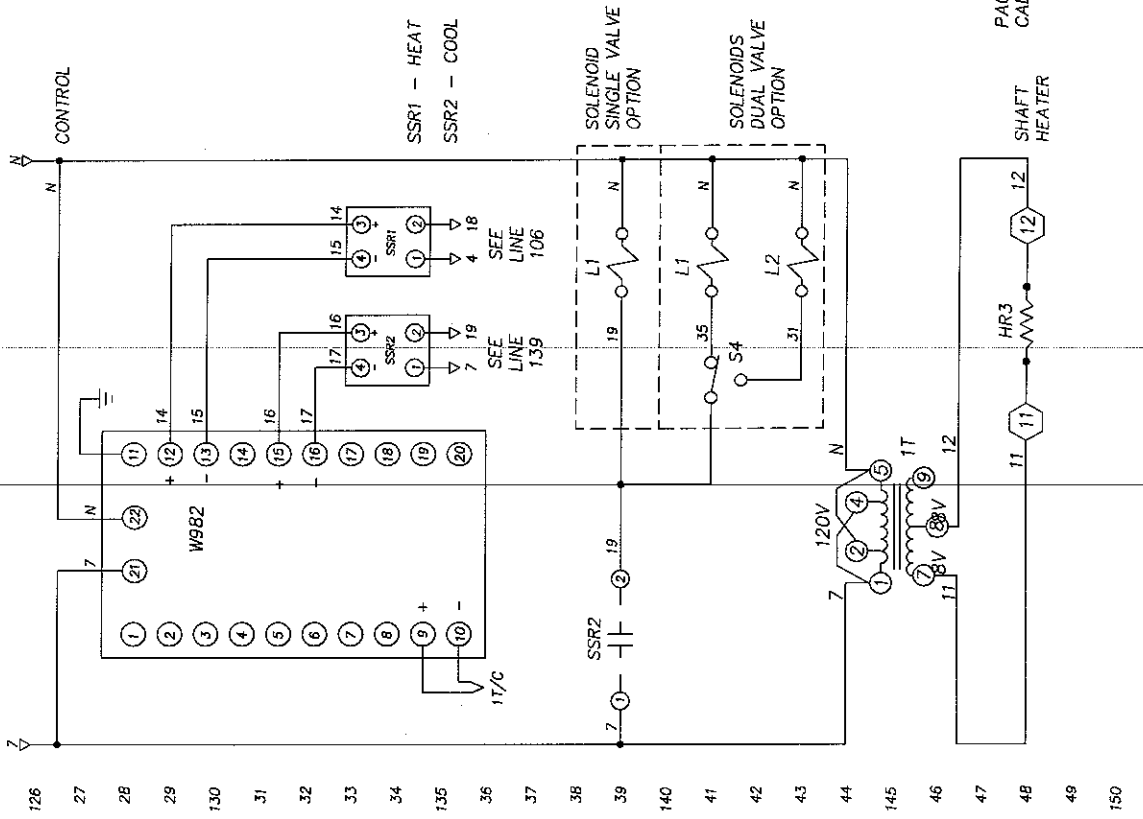

LIST OF MATERIAL

ITEM	PART NUMBER	QTY	DESCRIPTION
U1	1180087	1	8B2S-1000-C402 RES32/40S
U2	052326	1	BTI TYPE 1/2
U3	051852	1	0.05 WMC 30A 120V FLUG
U4	047852	1	TR 24-15-150 TRANSFORMER (LOCATED ON CHASSIS)
F1	265987	1	FUSIBLECK (USA) 1P
F2	007503	1	FNM/78M 3 2A FLUG
F3	265987	1	FUSIBLECK (USA) 1P
F4	044580	1	FNM/78M 3A ON FLUG
S1	044587	1	SW1CH DPST 0T-10AL-210M
S2	104608	1	R1440318 903 PAK STAT
R1	060705	1	RTD 1000 OHM FOR PAK STAT
R2	060777	1	THERMO CARTRIDGE 3A OPEN ON RISE
K1	047753	1	RELAY MOTOR 187-517201
SSR1	047610	1	RELAY SSR 224500 DC INPUT
SSR2	047611	1	RELAY SSR 224500 DC INPUT
HR1	053007	1	HEATER 115V 3000W
HR2	101970	1	HEATER 115V 350W
SS	101832	1	HEATER MOTOR SHAFT
HR3	062328	1	MOTOR 0.5HP 115V
BT	057348	1	CAPACITOR MOTOR 03 MFD 370V
CAP	134899	1	MLV SOL LND PREDYNE 225A 115V
U1	136689	1	MLV SOL LP002 PREDYNE 350W 115V
U2	136690	1	MLV SOL HP002 PREDYNE 1000W 115V
U3	132238	1	GROUND BUS (LOCATED ON CHASSIS)

DUAL VALVE OPTION

ITEM	PART NUMBER	QTY	DESCRIPTION
L2	136589	1	MLV SOL LP002 PREDYNE 350W 115V
L1	136590	1	MLV SOL HP002 PREDYNE 1000W 115V
S4	075143	1	LSW TIB 1125 SPDT

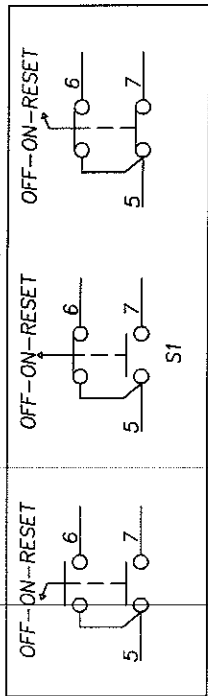
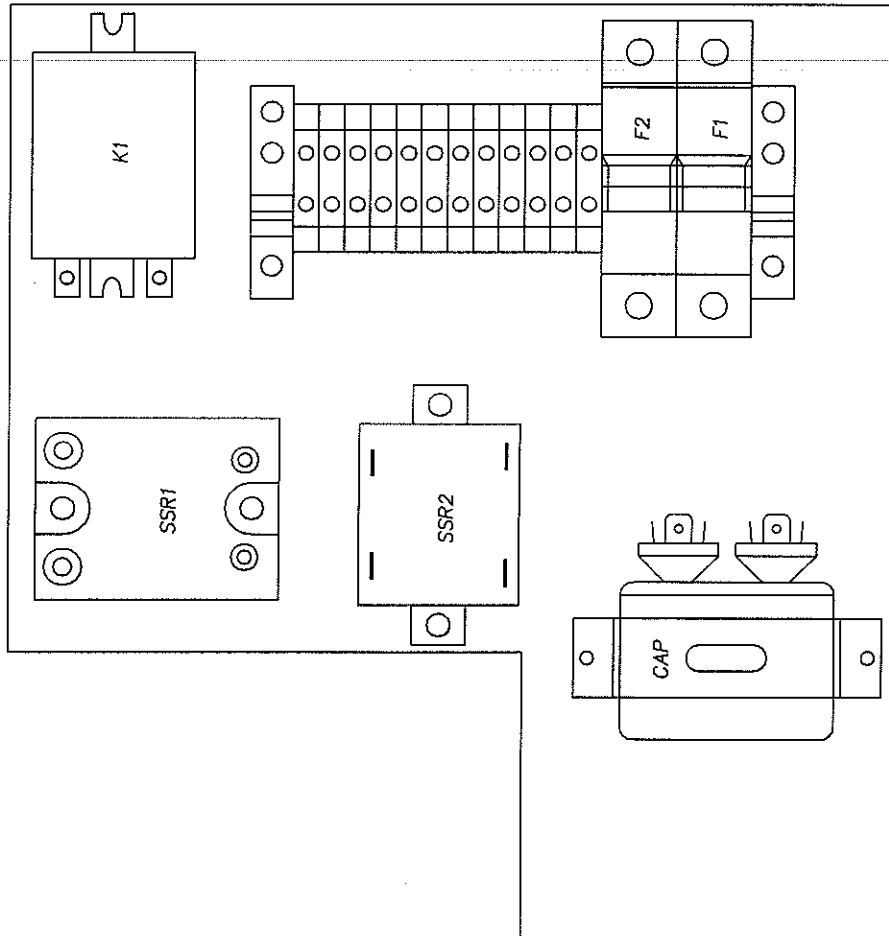

PAGE 2 OF 2
CAD FILE: 140316*1

925 Series w/982 Control
excerpt from drawing
140316A01

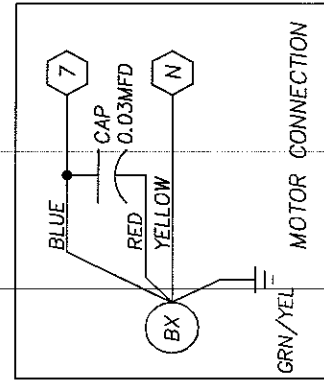

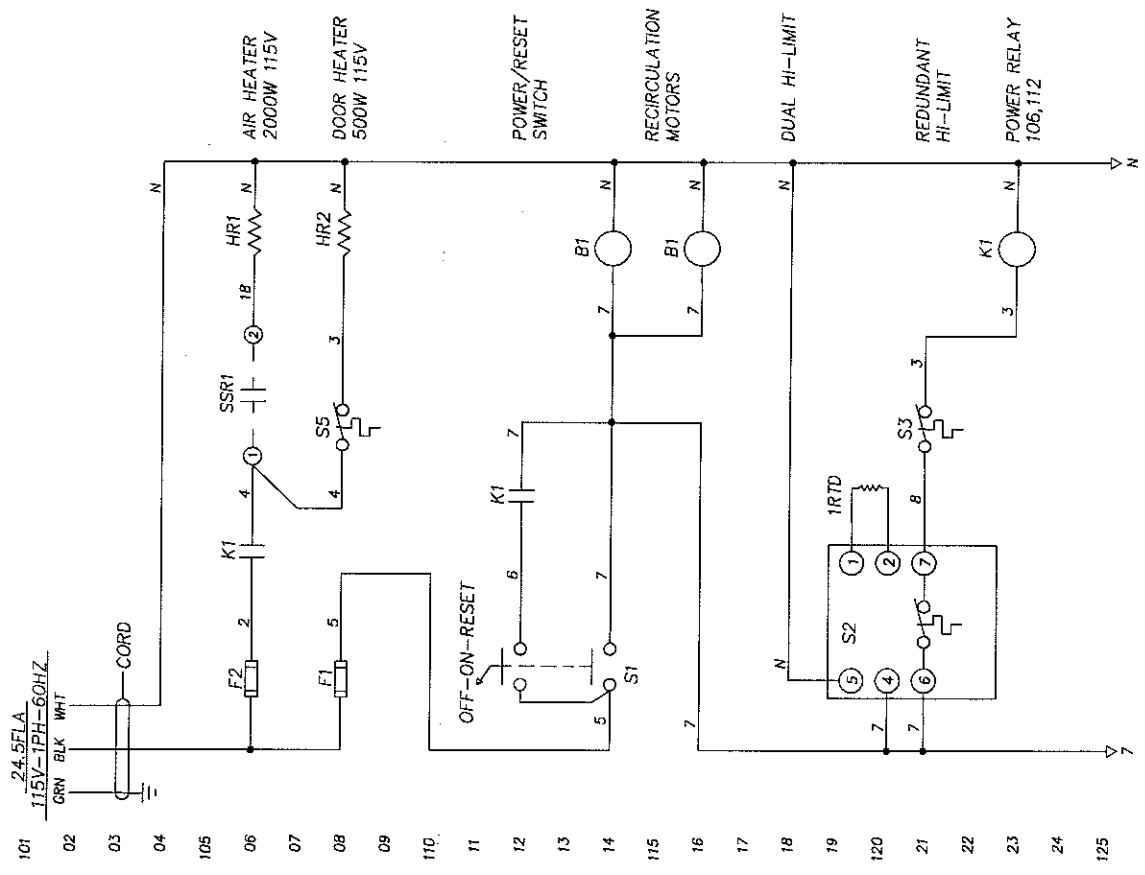
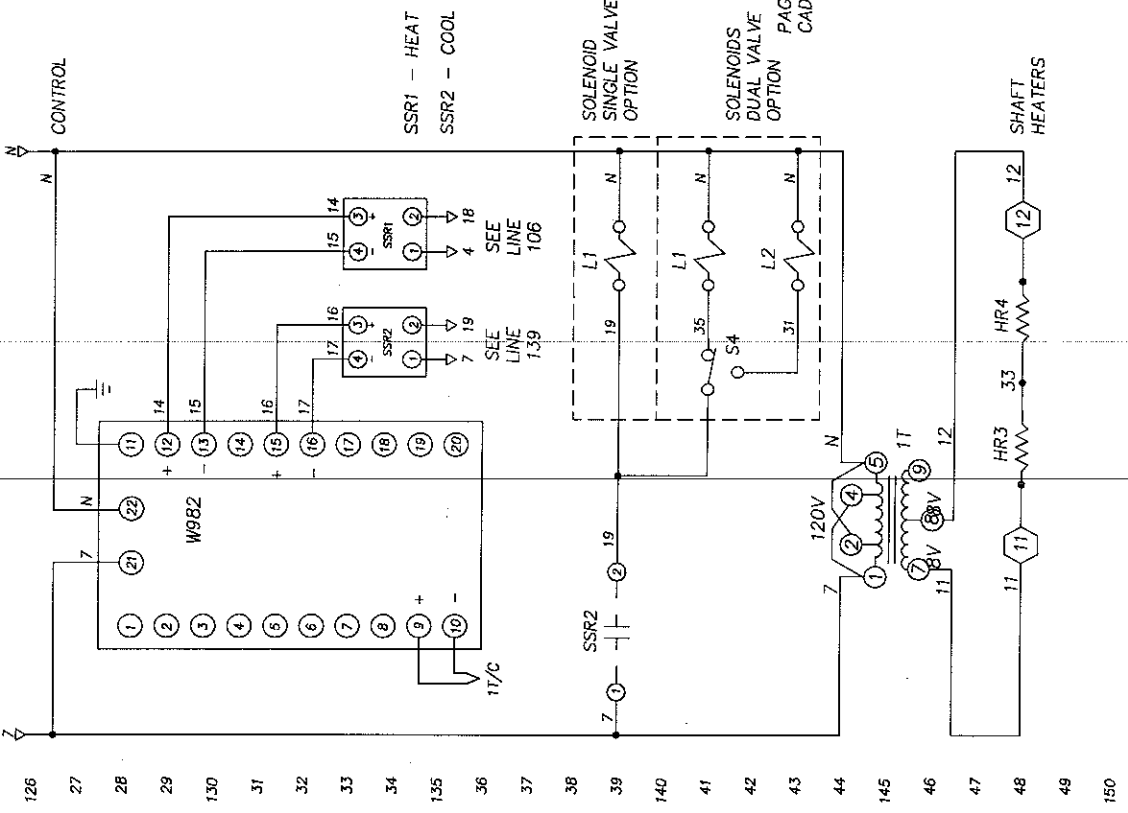

LIST OF MATERIAL		
ITEM	PART NUMBER	QTY
CI	119087	1
17/C	053325	7FT
GOBO	071822	1
1T	047617	1
F1	265987	1
F2	007503	1
S1	094090	1
S2	104609	1
RTD	080705	1
S3	080177	1
K1	047753	1
SSR1	047610	1
SSR2	047611	1
HR1	053007	1
HR2	102475	1
SS	101671	2
HR3-4	062327	2
BI-2	057348	2
CAP	134699	1
L1	136699	1
GND	136690	1
	132298	1

DUAL VALVE OPTION		
ITEM	PART NUMBER	QTY
L2	136689	1
S4	075143	1

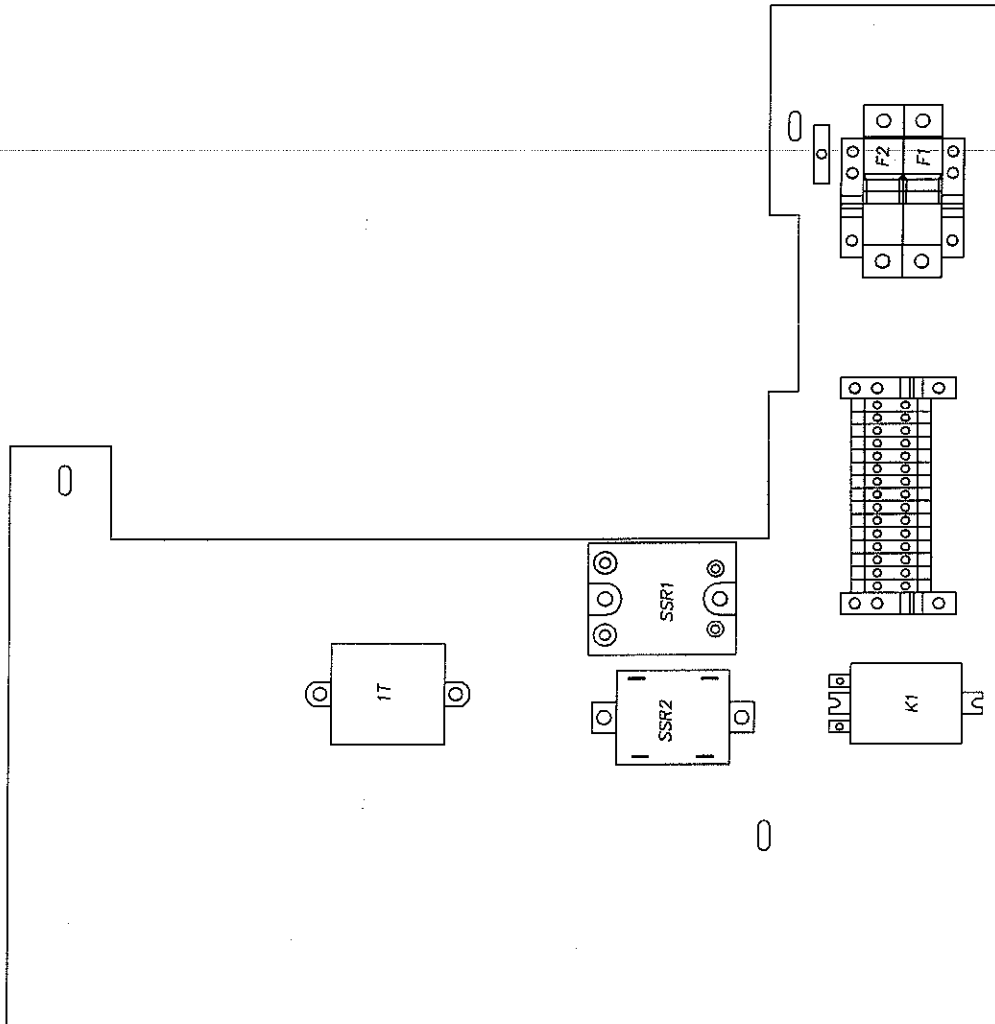

935 Series w/982 Control
 excerpt from drawing
 140318A01

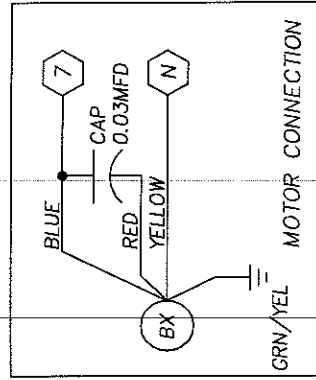
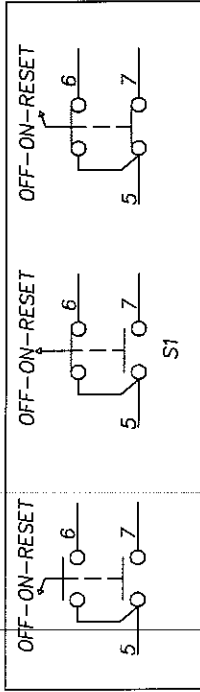

936 Series w/982 Control
 excerpt from drawing
 140320B00

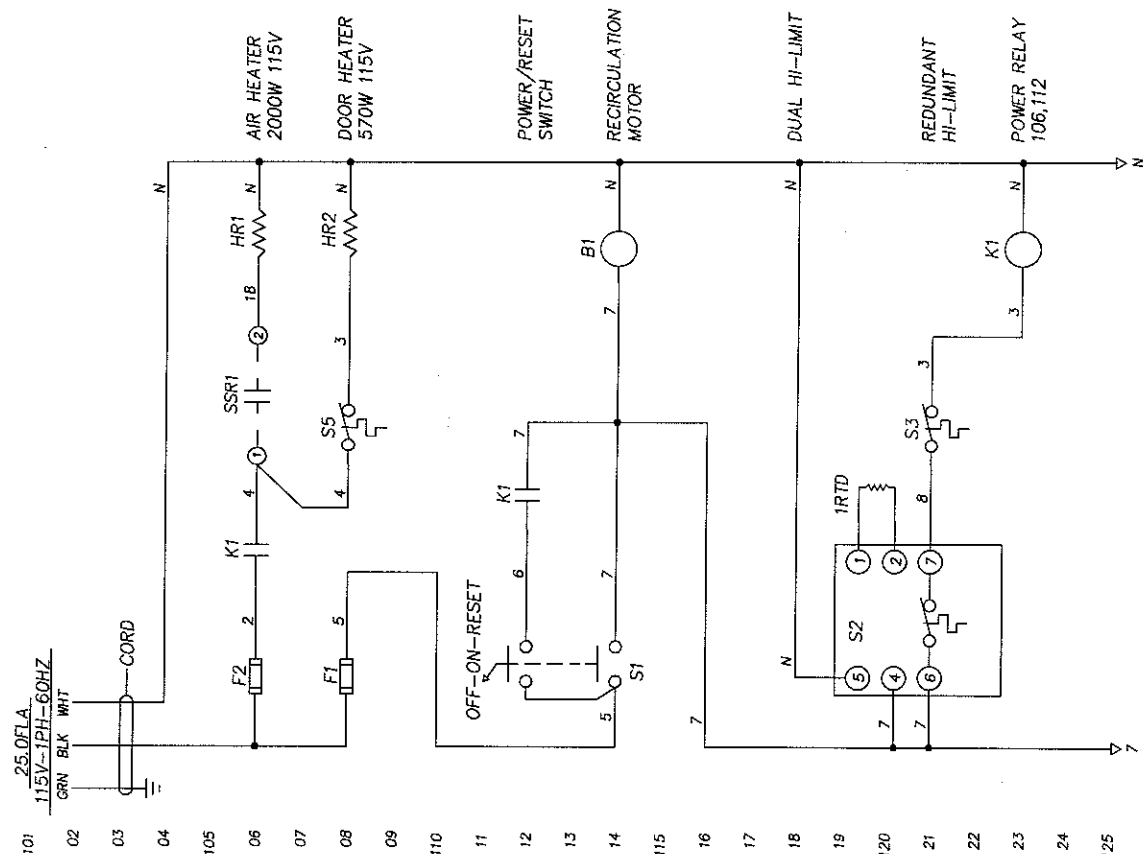
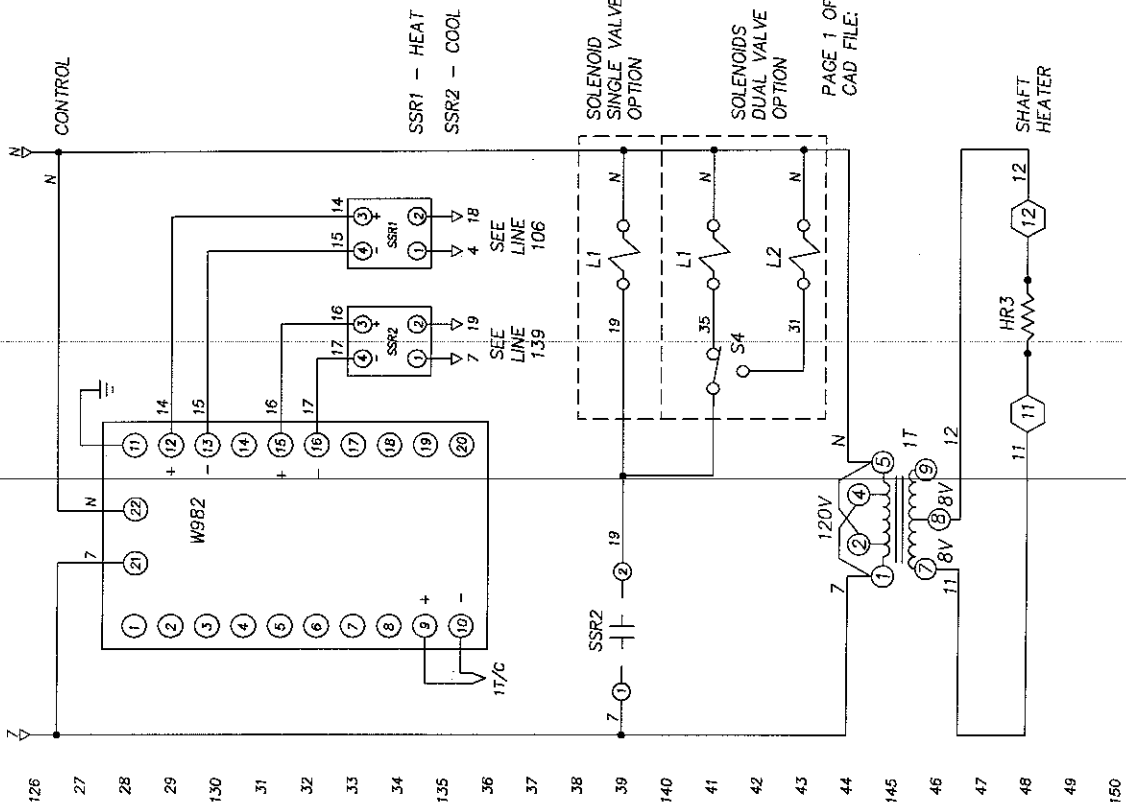

LIST OF MATERIAL			
ITEM	PART NUMBER	QTY	DESCRIPTION
C1	115097	1	9925-10CC-CUCD RS232/485
T/C	022255	1	TYPE T/20
C600	041867	1	99 24-48-148R TRANSFORMER (LOCATED ON CHASSIS)
F1	265082	1	FUSE/BLK 1/8"X1 1/2"
F2	027503	1	FUSE/GRN 1/8"X1 1/2"
S1	044600	1	SW/TTB 25 ON FUSE
S2	044600	1	SW/TTB 25 ON FUSE
S3	104602	1	SW/TTB 25 ON FUSE
S4	080205	1	SW/TTB 25 ON FUSE
S5	080205	1	SW/TTB 25 ON FUSE
S6	080205	1	SW/TTB 25 ON FUSE
S7	080205	1	SW/TTB 25 ON FUSE
S8	080205	1	SW/TTB 25 ON FUSE
S9	080205	1	SW/TTB 25 ON FUSE
S10	080205	1	SW/TTB 25 ON FUSE
S11	080205	1	SW/TTB 25 ON FUSE
S12	080205	1	SW/TTB 25 ON FUSE
S13	080205	1	SW/TTB 25 ON FUSE
S14	080205	1	SW/TTB 25 ON FUSE
S15	080205	1	SW/TTB 25 ON FUSE
S16	080205	1	SW/TTB 25 ON FUSE
S17	080205	1	SW/TTB 25 ON FUSE
S18	080205	1	SW/TTB 25 ON FUSE
S19	080205	1	SW/TTB 25 ON FUSE
S20	080205	1	SW/TTB 25 ON FUSE
S21	080205	1	SW/TTB 25 ON FUSE
S22	080205	1	SW/TTB 25 ON FUSE
S23	080205	1	SW/TTB 25 ON FUSE
S24	080205	1	SW/TTB 25 ON FUSE
S25	080205	1	SW/TTB 25 ON FUSE
S26	080205	1	SW/TTB 25 ON FUSE
S27	080205	1	SW/TTB 25 ON FUSE
S28	080205	1	SW/TTB 25 ON FUSE
S29	080205	1	SW/TTB 25 ON FUSE
S30	080205	1	SW/TTB 25 ON FUSE
S31	080205	1	SW/TTB 25 ON FUSE
S32	080205	1	SW/TTB 25 ON FUSE
S33	080205	1	SW/TTB 25 ON FUSE
S34	080205	1	SW/TTB 25 ON FUSE
S35	080205	1	SW/TTB 25 ON FUSE
S36	080205	1	SW/TTB 25 ON FUSE
S37	080205	1	SW/TTB 25 ON FUSE
S38	080205	1	SW/TTB 25 ON FUSE
S39	080205	1	SW/TTB 25 ON FUSE
S40	080205	1	SW/TTB 25 ON FUSE
S41	080205	1	SW/TTB 25 ON FUSE
S42	080205	1	SW/TTB 25 ON FUSE
S43	080205	1	SW/TTB 25 ON FUSE
S44	080205	1	SW/TTB 25 ON FUSE
S45	080205	1	SW/TTB 25 ON FUSE
S46	080205	1	SW/TTB 25 ON FUSE
S47	080205	1	SW/TTB 25 ON FUSE
S48	080205	1	SW/TTB 25 ON FUSE
S49	080205	1	SW/TTB 25 ON FUSE
S50	080205	1	SW/TTB 25 ON FUSE
S51	080205	1	SW/TTB 25 ON FUSE
S52	080205	1	SW/TTB 25 ON FUSE
S53	080205	1	SW/TTB 25 ON FUSE
S54	080205	1	SW/TTB 25 ON FUSE
S55	080205	1	SW/TTB 25 ON FUSE
S56	080205	1	SW/TTB 25 ON FUSE
S57	080205	1	SW/TTB 25 ON FUSE
S58	080205	1	SW/TTB 25 ON FUSE
S59	080205	1	SW/TTB 25 ON FUSE
S60	080205	1	SW/TTB 25 ON FUSE
S61	080205	1	SW/TTB 25 ON FUSE
S62	080205	1	SW/TTB 25 ON FUSE
S63	080205	1	SW/TTB 25 ON FUSE
S64	080205	1	SW/TTB 25 ON FUSE
S65	080205	1	SW/TTB 25 ON FUSE
S66	080205	1	SW/TTB 25 ON FUSE
S67	080205	1	SW/TTB 25 ON FUSE
S68	080205	1	SW/TTB 25 ON FUSE
S69	080205	1	SW/TTB 25 ON FUSE
S70	080205	1	SW/TTB 25 ON FUSE
S71	080205	1	SW/TTB 25 ON FUSE
S72	080205	1	SW/TTB 25 ON FUSE
S73	080205	1	SW/TTB 25 ON FUSE
S74	080205	1	SW/TTB 25 ON FUSE
S75	080205	1	SW/TTB 25 ON FUSE
S76	080205	1	SW/TTB 25 ON FUSE
S77	080205	1	SW/TTB 25 ON FUSE
S78	080205	1	SW/TTB 25 ON FUSE
S79	080205	1	SW/TTB 25 ON FUSE
S80	080205	1	SW/TTB 25 ON FUSE
S81	080205	1	SW/TTB 25 ON FUSE
S82	080205	1	SW/TTB 25 ON FUSE
S83	080205	1	SW/TTB 25 ON FUSE
S84	080205	1	SW/TTB 25 ON FUSE
S85	080205	1	SW/TTB 25 ON FUSE
S86	080205	1	SW/TTB 25 ON FUSE
S87	080205	1	SW/TTB 25 ON FUSE
S88	080205	1	SW/TTB 25 ON FUSE
S89	080205	1	SW/TTB 25 ON FUSE
S90	080205	1	SW/TTB 25 ON FUSE
S91	080205	1	SW/TTB 25 ON FUSE
S92	080205	1	SW/TTB 25 ON FUSE
S93	080205	1	SW/TTB 25 ON FUSE
S94	080205	1	SW/TTB 25 ON FUSE
S95	080205	1	SW/TTB 25 ON FUSE
S96	080205	1	SW/TTB 25 ON FUSE
S97	080205	1	SW/TTB 25 ON FUSE
S98	080205	1	SW/TTB 25 ON FUSE
S99	080205	1	SW/TTB 25 ON FUSE
S100	080205	1	SW/TTB 25 ON FUSE

DUAL VALVE OPTION			
ITEM	PART NUMBER	QTY	DESCRIPTION
L2	136689	1	M.V. SOL. LP002 PREDIYNE 350# 115V
L3	136690	1	M.V. SOL. HP002 PREDIYNE 1000# 115V
S4	075143	1	SW. TTB 1125 SPDT

936 Series w/982 Control
 excerpt from drawing
 140320B01

